



YAMAHA

GENUINE

PARTS CATALOGUE

MOTORCYCLE

CYLINDER

Ref. No.	Part Number	Description	Qty	Remarks
1	(5F7-11111-00-00)	HEAD, CYLINDER 1	2	
2	90338-06041-00	PLUG	2	
3	90430-06166-00	GASKET	2	
4	93210-62323-00	O-RING (93210-63442-00)	2	
5	93211-14421-00	O-RING	2	
7	93604-08071-00	PIN, DOWEL	4	
8	95811-08045-00	BOLT, FLANGE (JN5)	8	
9	(5F7-11310-01-00)	CYLINDER	2	
10	(4A0-11375-00-00)	NIPPLE, HOSE 1	2	
11	(4A0-W0024-00-00)	VALVE FITTING SET	4	
12	4A0-1131H-00-00	JOINT 1	1	
13	4A0-1131J-01-00	JOINT 2	1	
14	90149-05149-00	SCREW	2	
15	4A0-11351-00-00	GASKET, CYLINDER	2	
16	(4A0-11361-00-00)	BOLT, CYLINDER HOLDING 1	4	
17	(4A0-11362-00-00)	BOLT, CYLINDER HOLDING 2	4	
18	90179-08246-00	NUT, SPEC'L SHAPE	8	
19	99510-10114-00	PIN, DOWEL	4	
20	(90445-10139-00)	HOSE	2	
21	90340-10016-00	PLUG, STRAIGHT SCRW (383-11374-00)	4	

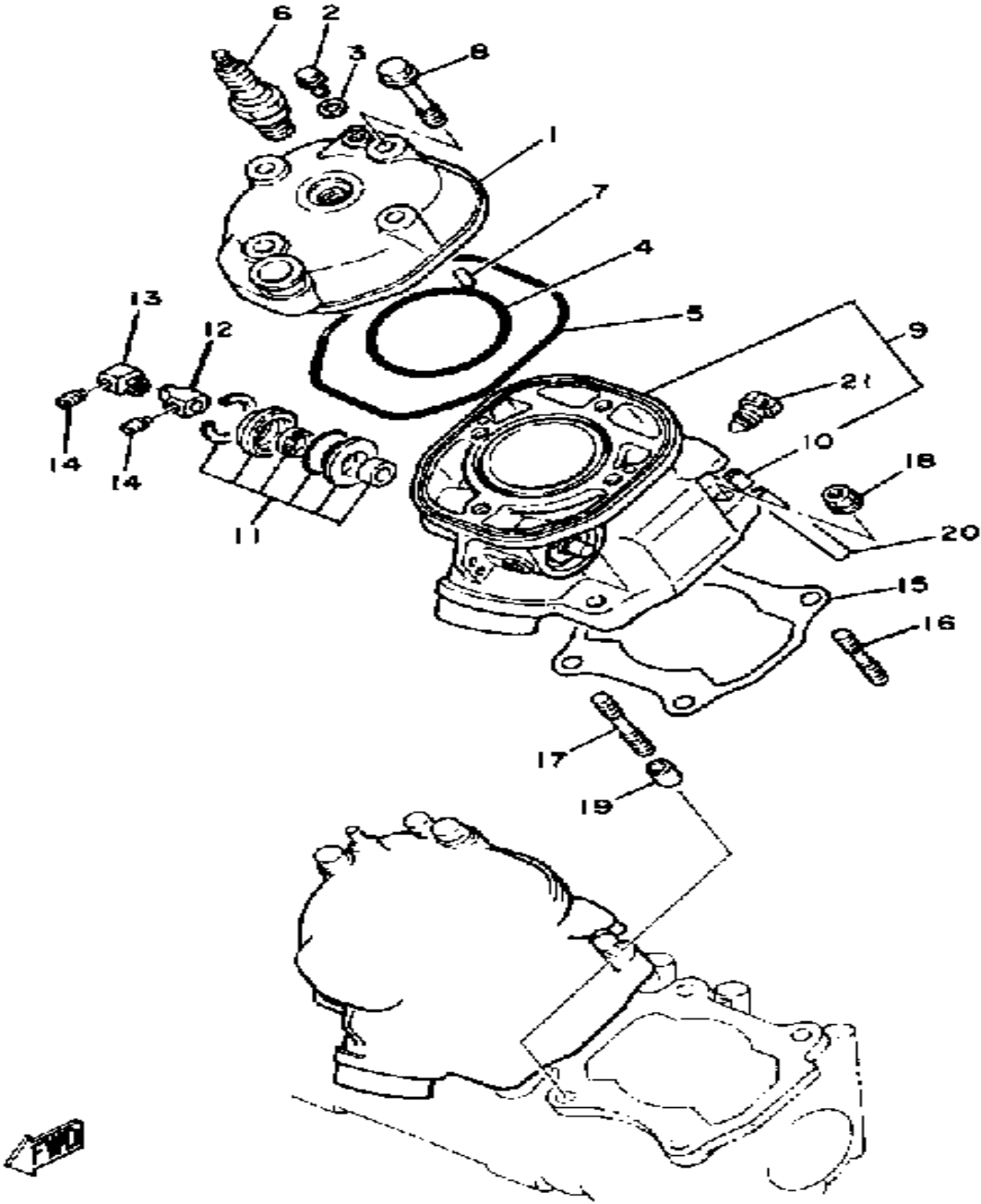

GOVERNOR

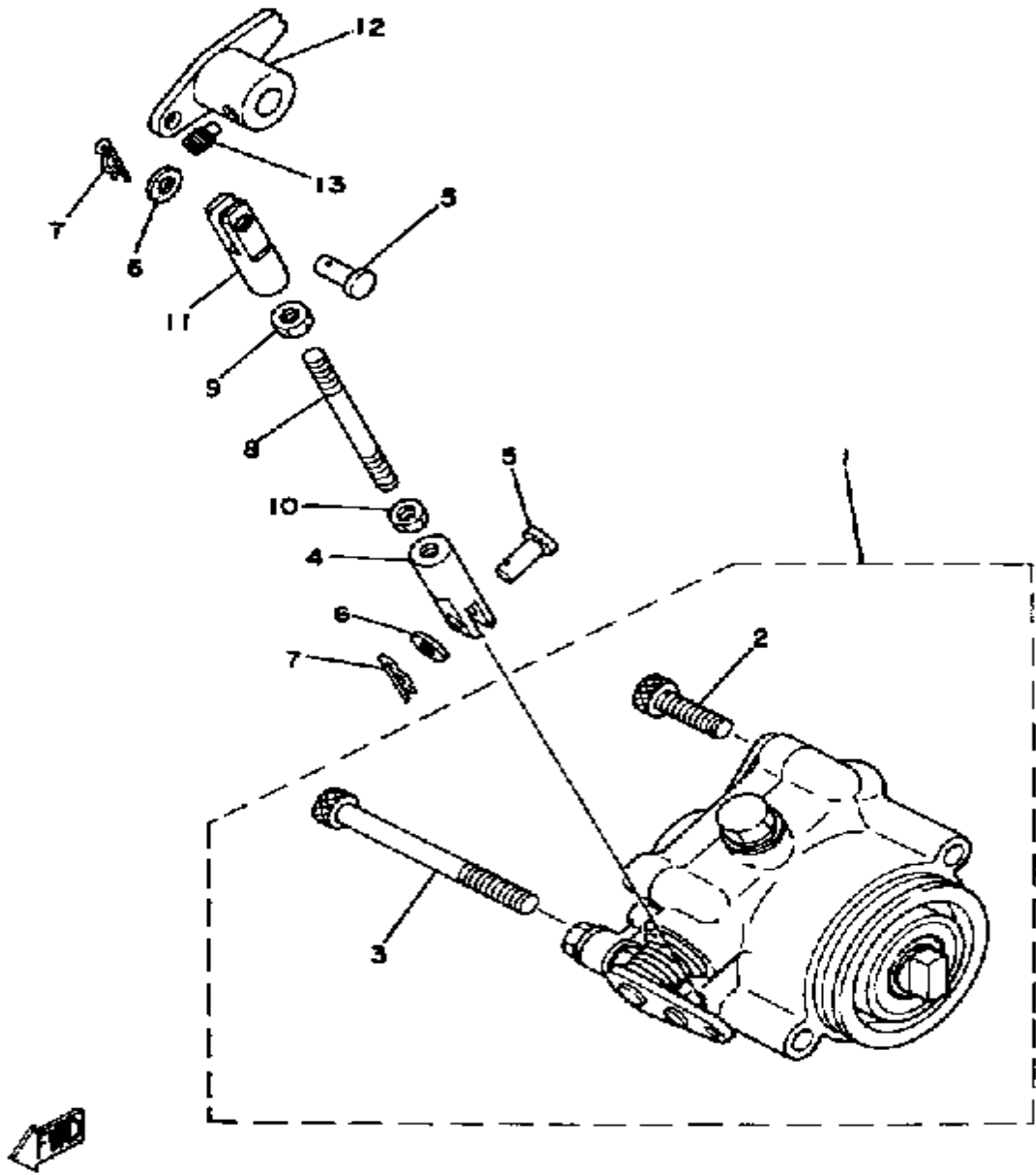

Ref. No.	Part Number	Description	Qty	Remarks
1	(26J-11901-00-00)	GOVERNOR ASSEMBLY	1	
2	91316-06020-00	. BOLT, SOCKET HEAD	3	
3	91316-06065-00	. BOLT, SOCKET HEAD	3	
4	5F7-11998-00-00	BRACKET 1	1	
5	(90240-05044-00)	PIN, CLEVIS	2	
6	90201-05328-00	WASHER, PLATE	2	
7	90468-10050-00	CLIP	2	
8	(5F7-11983-00-00)	ROD, PUSH	1	
9	95311-05700-00	NUT	1	
10	90170-05190-00	NUT, HEXAGON	1	
11	(5F7-11999-00-00)	BRACKET 2	1	
12	(5F7-11931-00-00)	LEVER	1	
13	90149-05149-00	SCREW	1	

CRANKSHAFT - PISTON

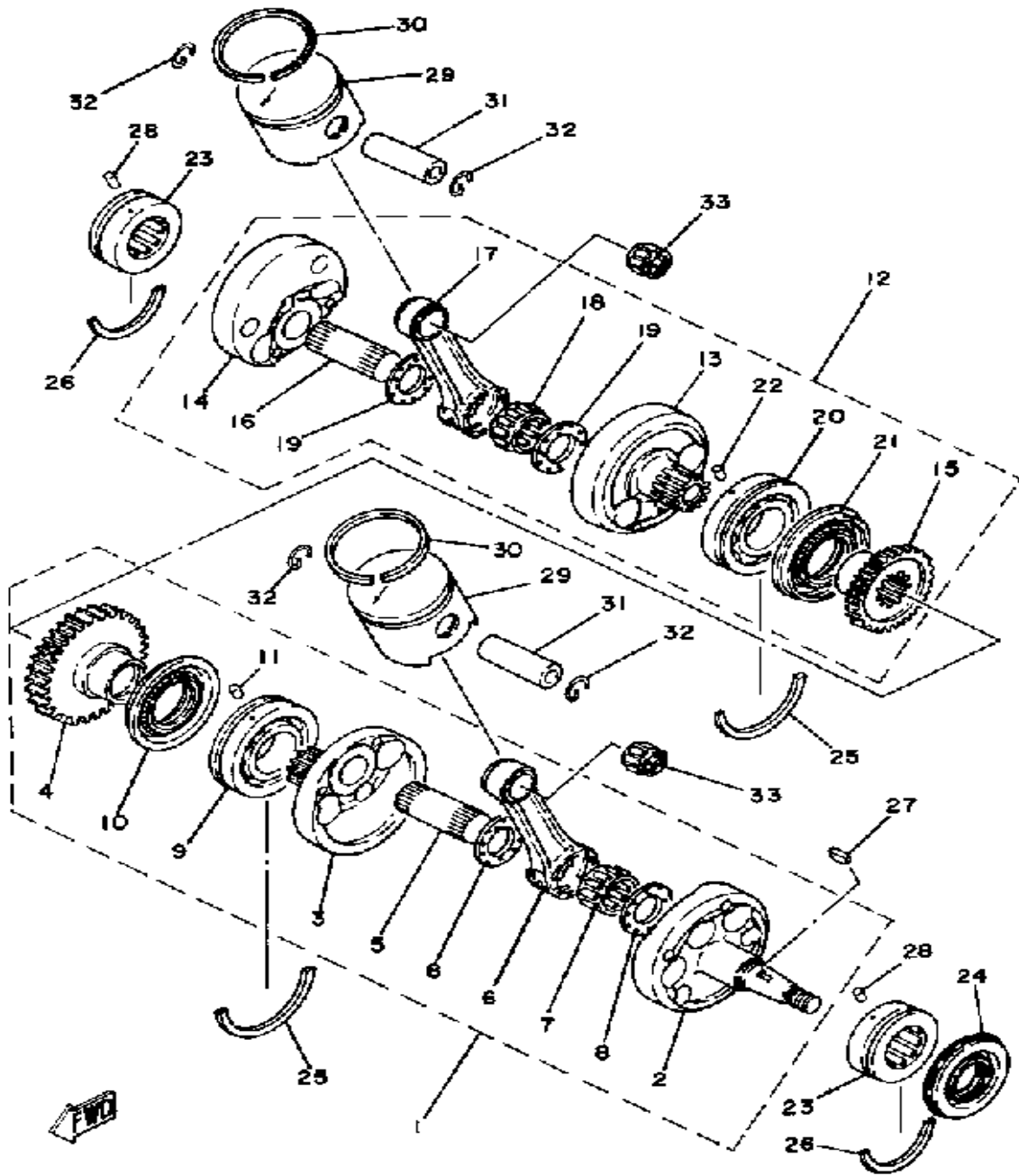

Ref. No.	Part Number	Description	Qty	Remarks
1	(5F7-11401-00-00)	CRANK SUB ASSEMBLY 1	1	
2	5F7-11412-00-00	. CRANK 1	1	
3	(5F7-11422-00-00)	CRANK 2	1	
4	5F7-11536-00-00	. GEAR, DRIVE	1	
5	5F7-11681-00-00	. PIN, CRANK 1	1	
6	49V-11651-00-00	. ROD, CONNECTING	1	
7	93310-522N9-00	. BEARING, CYLINDER.# 0	1	
8	90209-22248-00	. WASHER	2	
9	93306-20638-00	. BEARING 3TC	1	
10	93103-37122-00	. OIL SEAL, SW-TYPE	1	
11	93603-09106-00	. PIN, DOWEL	1	
12	(5F7-11402-00-00)	CRANK SUB ASSEMBLY 2	1	
13	(5F7-11422-00-00)	CRANK 2	1	
14	(5F7-11432-00-00)	CRANK 3	1	
15	5F7-11434-00-00	. GEAR, CRANK SHAFT	1	
16	5F7-11681-00-00	. PIN, CRANK 1	1	
17	49V-11651-00-00	. ROD, CONNECTING	1	
18	93310-522N9-00	. BEARING, CYLINDER.# 0	1	
19	90209-22248-00	. WASHER	2	
20	93306-20638-00	. BEARING 3TC	1	
21	93103-37122-00	. OIL SEAL, SW-TYPE	1	
22	93603-09106-00	. PIN, DOWEL	1	
23	93311-82547-00	BEARING, CYLINDER.# 1	2	
24	93103-25121-00	OIL SEAL, SW-TYPE	1	
25	93440-66095-00	CIRCLIP, OUTER	2	
26	278-17414-00-00	CLIP	2	
27	90280-04005-00	KEY, WOODRUFF	1	
28	93603-09106-00	PIN, DOWEL	2	
29	4A0-11631-00-96	PISTON STD	2	U.R.

CONTINUED ON NEXT FRAME ►

CRANKSHAFT - PISTON

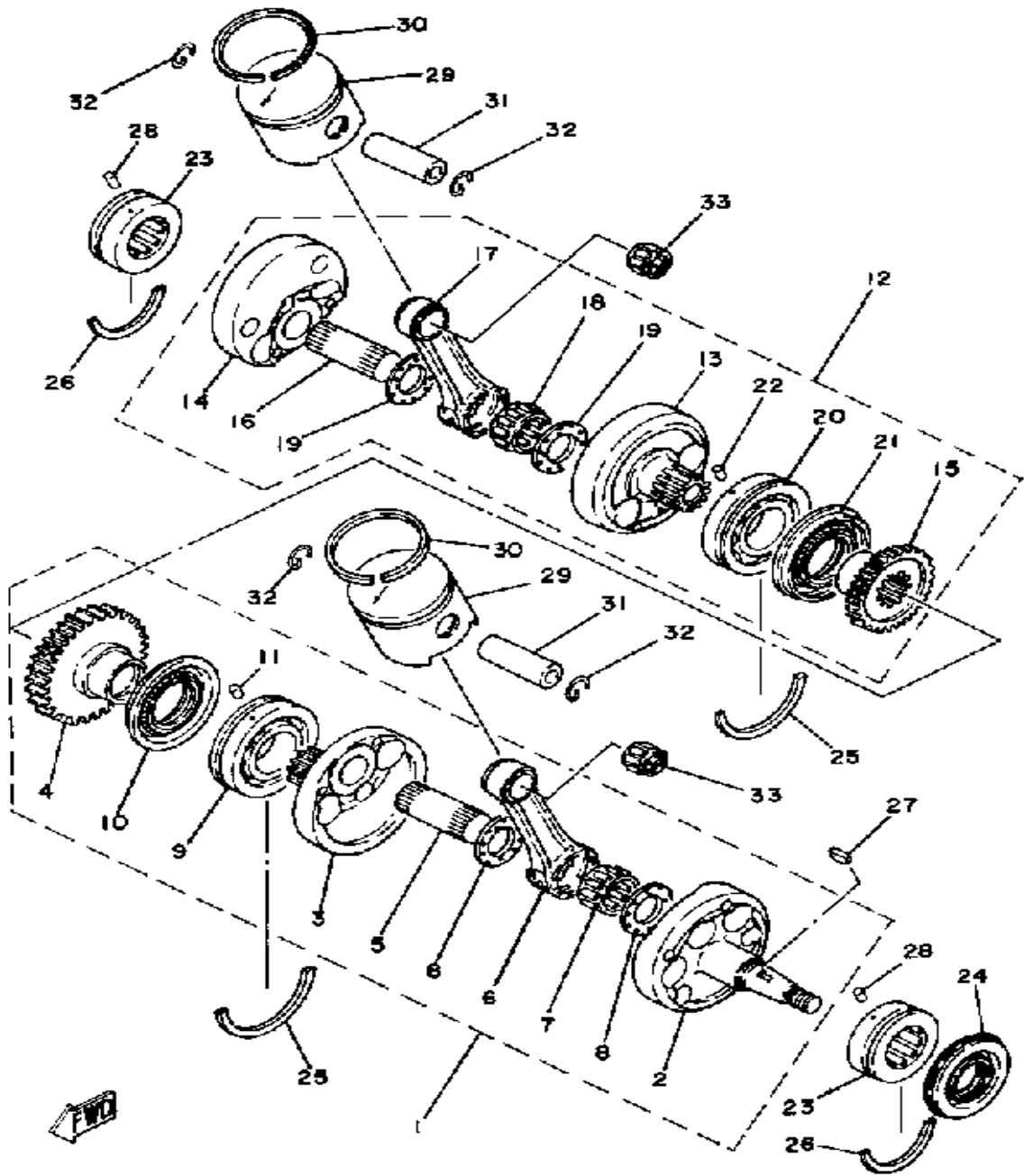

Ref. No.	Part Number	Description	Qty	Remarks
29	4A0-11631-00-97	PISTON STD	2	U.R.
	4A0-11631-00-98	PISTON STD	2	U.R.
30	240-11611-00-00	RING, PISTON STD	2	
31	137-11633-00-00	PIN, PISTON	2	
32	4A0-11634-00-00	CLIP, PISTON PIN	4	
33	93310-216L2-00	BEARING, CYLINDRICAL	2	

COUNTER SHAFT

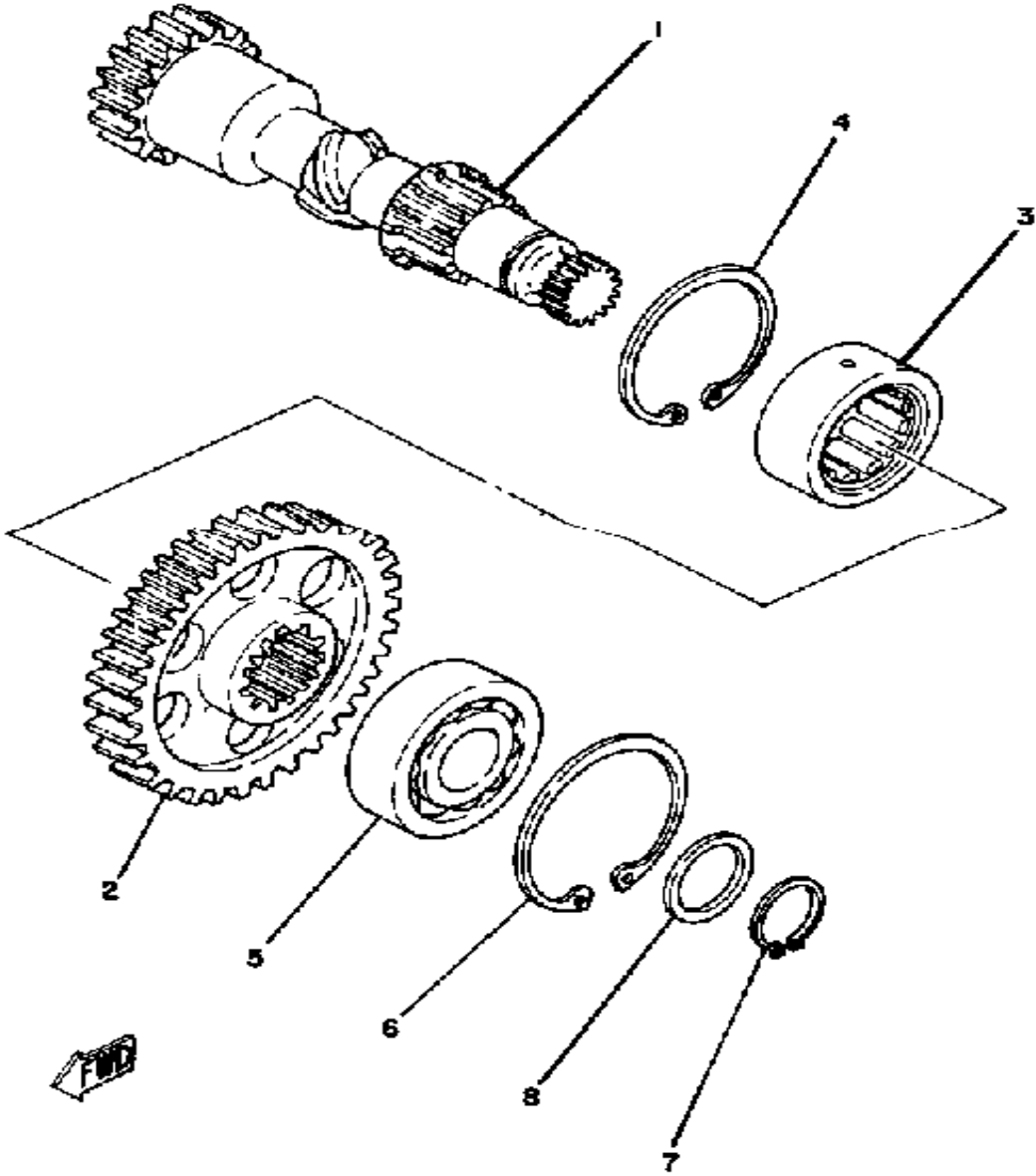

Ref. No.	Part Number	Description	Qty	Remarks
1	(5F7-11455-00-00)	SHAFT 1	1	
2	5F7-11537-01-00	GEAR, DRIVEN	1	
3	93311-43048-00	BEARING	1	
4	99009-42500-00	CIRCLIP	1	
5	93306-20421-00	BEARING	1	
6	99009-47500-00	CIRCLIP	1	
7	93410-20021-00	CIRCLIP, S-TYPE	1	
8	90201-20266-00	WASHER, PLATE (1.0T)	1	

C - D - I MAGNETO

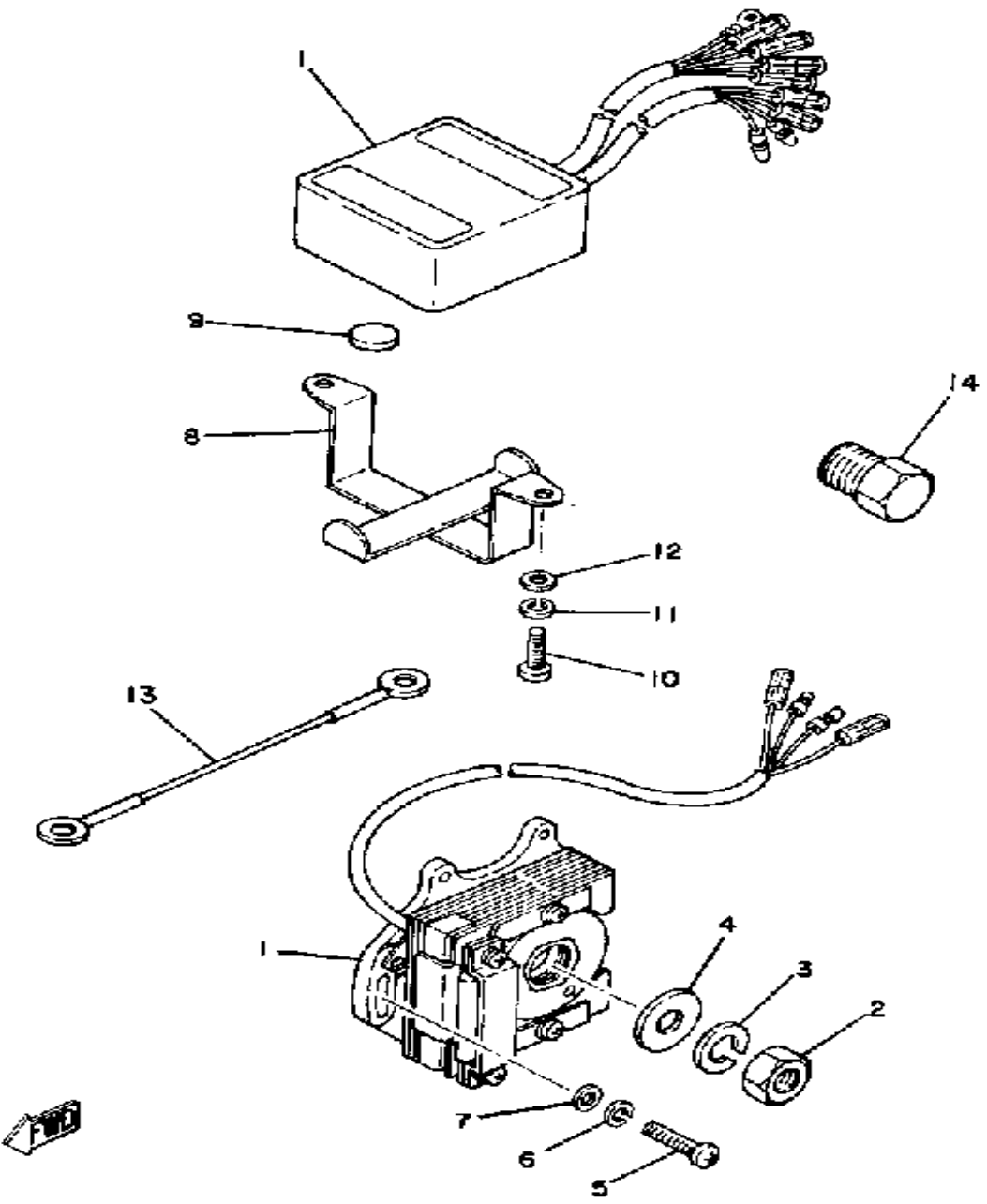

Ref. No.	Part Number	Description	Qty	Remarks
1	5F7-W8551-11-00	CDI MAG & UNIT SET	1	
2	90170-12060-00	NUT	1	
3	92901-12100-00	WASHER, SPRING	1	
4	90201-16513-00	WASHER, PLATE (12.5-30-2.6)	1	
5	98580-06020-00	SCREW	2	
6	92995-06100-00	WASHER, SPRING	2	
7	92901-06600-00	WASHER	2	
8	5F7-85542-00-00	BRACKET	1	
9	4A0-85547-00-00	DAMPER	6	
10	98580-06020-00	SCREW	2	
11	92995-06100-00	WASHER, SPRING	2	
12	92901-06600-00	WASHER	2	
13	5F7-82519-00-00	WIRE, EARTH LEAD	1	
14	(90109-20405-00)	BOLT	1	

WATER PUMP

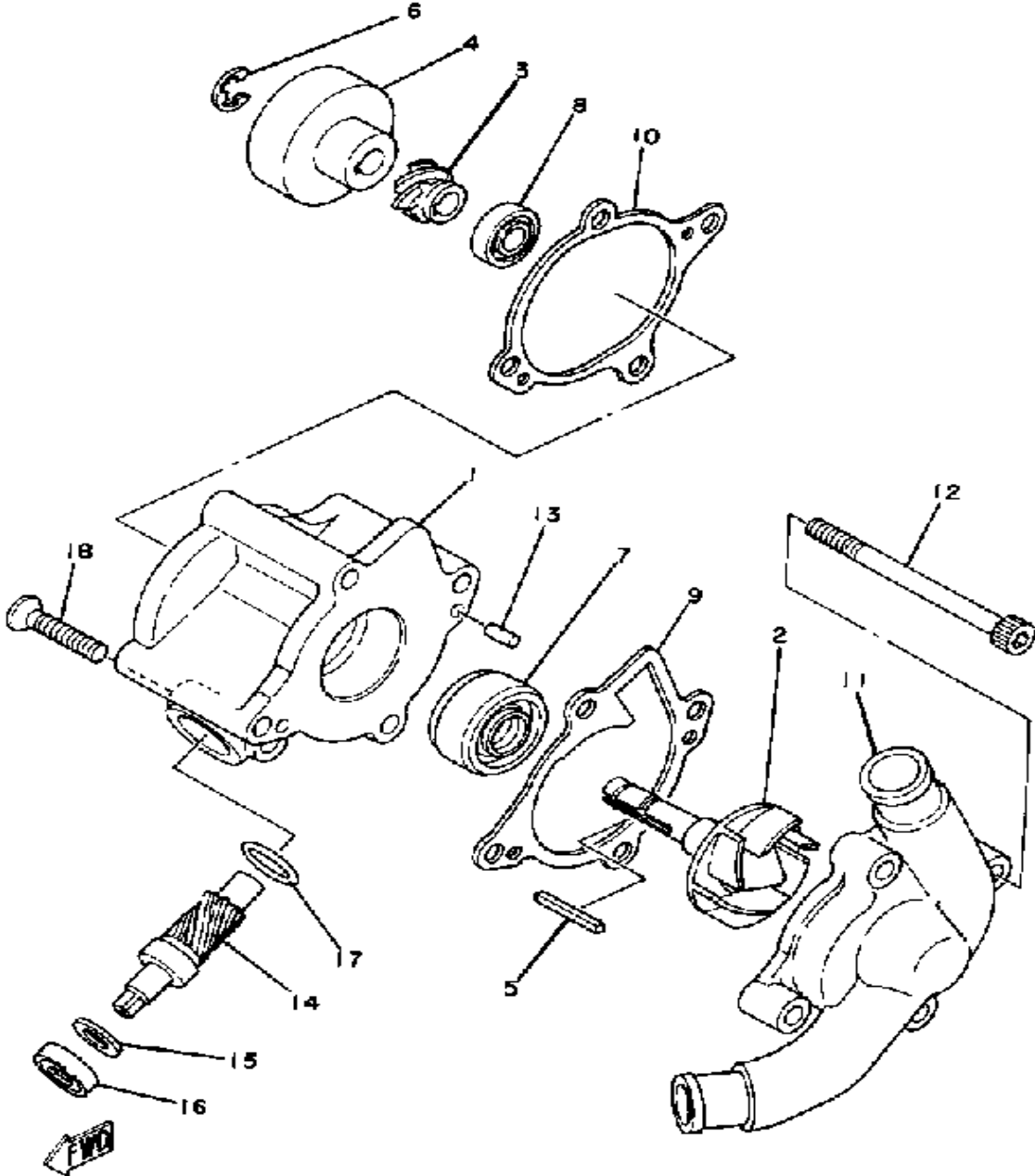

Ref. No.	Part Number	Description	Qty	Remarks
1	(5F7-12421-00-00)	HOUSING, WATER PUMP	1	
2	(5F7-12450-00-00)	IMPELLER SHAFT ASSEMBLY	1	
3	5F7-17831-00-00	GEAR, DRIVE	1	
4	(5F7-12459-00-00)	GEAR, IMPELLER SHAF	1	
5	90282-03044-00	KEY, STRAIGHT	1	
6	99080-07600-00	CIRCLIP (E)	1	
7	93103-12119-00	OIL SEAL	1	
8	93300-62805-00	BEARING	1	
9	5F7-12427-00-00	GASKET, HSNQ CVR 1	1	
10	1RK-12428-00-00	GASKET, HOUSING 2	1	
11	(5F7-12422-00-00)	COVER, HOUSING	1	
12	91316-06075-00	BOLT, SOCKET HEAD	4	
13	93604-10011-00	PIN, DOWEL	2	
14	5F7-17841-00-00	GEAR, DRIVEN	1	
15	90201-12M34-00	WASHER, PLATE	1	
16	93102-08307-00	OIL SEAL	1	
17	93210-14104-00	O-RING	1	
18	92601-06030-00	SCREW, OVAL HEAD	1	

RADIATOR - HOSE

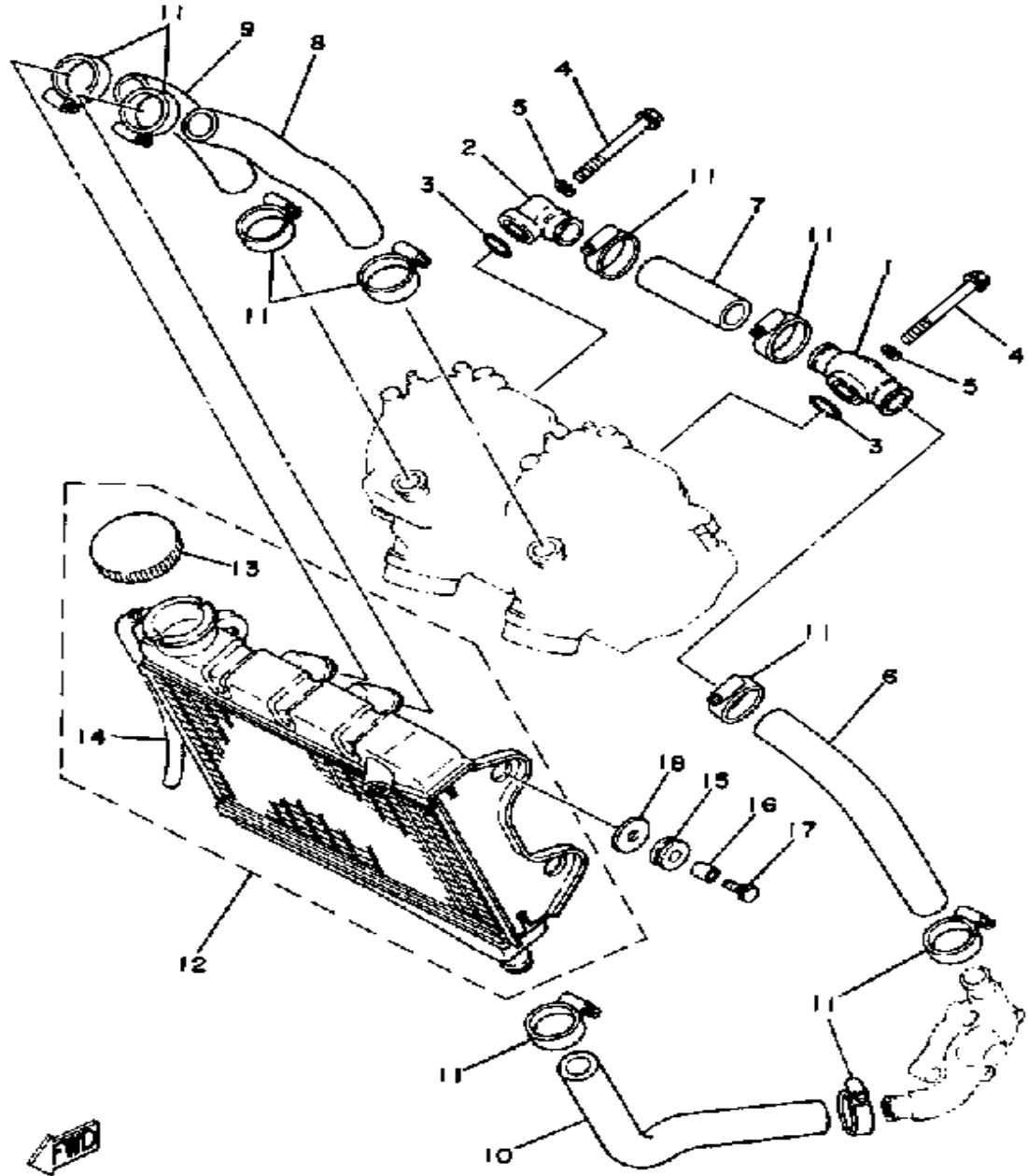

Ref. No.	Part Number	Description	Qty	Remarks
1	(5F7-12581-00-00)	JOINT, HOSE 1	1	
2	(5F7-12582-00-00)	JOINT, HOSE 2	1	
3	93210-20027-00	O-RING	2	
4	95811-08065-00	BOLT, FLANGE	2	
5	90201-08087-00	WASHER, PLATE	2	
6	5F7-12481-00-00	PIPE 1	1	
7	59W-12482-00-00	PIPE 2	1	
8	5F7-12483-00-00	PIPE 3	1	
9	5F7-12484-00-00	PIPE 4	1	
10	5F7-12485-00-00	PIPE 5	1	
11	90460-22110-00	CLAMP, HOSE	10	
12	(5F7-12460-00-00)	RADIATOR ASSEMBLY	1	
13	11H-12462-00-00	. CAP, RADIATOR	1	
14	(5F7-12463-00-00)	PIPE, BREATHER	1	
15	90480-18276-00	GROMMET	4	
16	90560-07007-00	SPACER	4	
17	90101-06288-00	BOLT	4	
18	90201-06074-00	WASHER, PLATE	4	

OIL PUMP

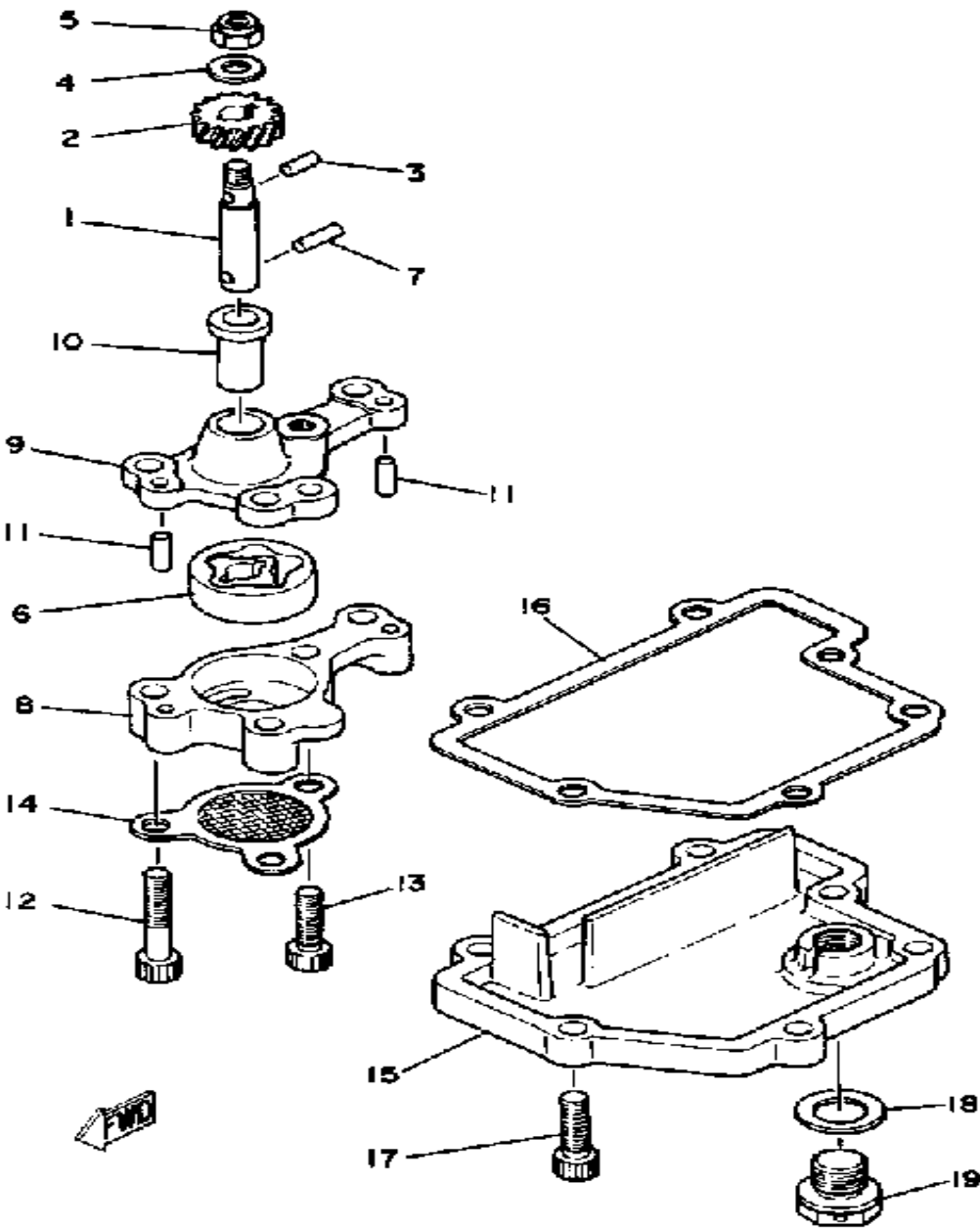

Ref. No.	Part Number	Description	Qty	Remarks
1	(5F7-13314-00-00)	SHAFT, PUMP	1	
2	5F7-13325-00-00	GEAR, PUMP DRIVEN	1	
3	93603-09106-00	PIN, DOWEL	1	
4	92990-06200-00	WASHER	1	
5	95601-06100-00	NUT, U	1	
6	5F7-13310-00-00	ROTOR ASSEMBLY 1	1	
7	93603-12007-00	PIN, DOWEL	1	
8	5F7-13336-00-00	HOUSING, ROTOR	1	
9	5F7-13316-00-00	COVER, PUMP	1	
10	(90386-08105-00)	BUSH, SPEC'L NYLON	1	
11	93604-18100-00	PIN, DOWEL	2	
12	90110-06138-00	BOLT, HEX SKT HEAD	3	
13	91316-06020-00	BOLT, SOCKET HEAD	1	
14	5F7-13411-00-00	STRAINER, OIL	1	
15	(26J-13417-00-00)	COVER, STRAINER	1	
16	5F7-13414-00-00	GASKET, STRNR COVER	1	
17	91316-06020-00	BOLT, SOCKET HEAD	5	
18	90430-12207-00	GASKET	1	
19	90109-12621-00	BOLT	1	

CARBURETOR

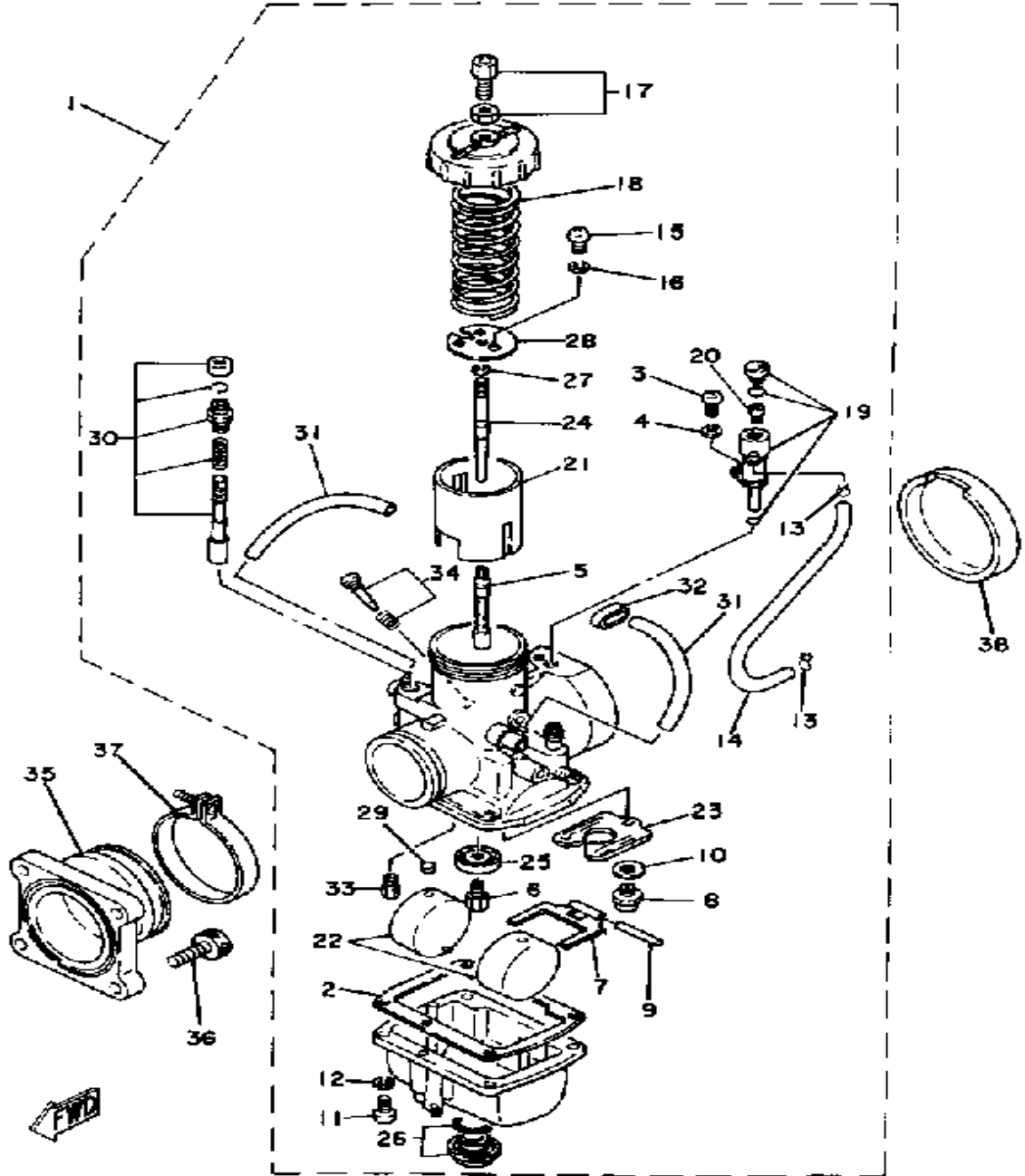

Ref. No.	Part Number	Description	Qty	Remarks
1	(5F7-14101-00-00)	CARBURETOR ASSEMBLY 1	2	
2	363-14184-00-00	. GASKET, FLOAT CHMBR	1	
3	98580-04010-00	. SCREW, PAN HEAD	1	
4	92901-04100-00	. WASHER, SPRING	1	
5	(239-14141-30-00)	NOZZLE, MAIN	1	
6	137-14143-72-00	. JET, MAIN (#360)	1	U.R.
	137-14143-74-00	. JET, MAIN (#370)	1	U.R.
	137-14143-76-00	. JET, MAIN (#380)	1	U.R.
	137-14143-78-00	. JET, MAIN (#390)	1	U.R.STD
	137-14143-80-00	. JET, MAIN (#400)	1	U.R.
	137-14143-82-00	. JET, MAIN (#410)	1	U.R.
	137-14143-84-00	. JET, MAIN (#420)	1	U.R.
	137-14143-86-00	. JET, MAIN (#430)	1	U.R.
	137-14143-88-00	. JET, MAIN (#440)	1	U.R.
7	363-14187-00-00	. ARM, FLOAT	1	
8	24X-14107-30-00	. NEEDLE VALVE SET (239-14190-30) (3.0)	1	
9	537-14186-00-00	. PIN, FLOAT	1	
10	239-14195-00-00	. WASHER, NEEDLE VALVE	2	
11	98580-05016-00	. SCREW, PAN HEAD	4	
12	92990-05100-00	. WASHER, SPRING	4	
13	8A7-14139-00-00	. CLIP, PIPE	2	
14	(3G2-14987-00-00)	HOSE	1	
15	98511-04006-00	. SCREW, PAN HEAD (98501-04005)	1	
16	92901-04100-00	. WASHER, SPRING	1	
17	12G-14106-00-00	. CABLE ADJUST SCREW SET	1	
18	(3G2-14131-00-00)	SPRING, THRTL VALVE	1	
19	5F7-W1416-00-00	. JET HOLDER SET	1	

CONTINUED ON NEXT FRAME ►

CARBURETOR

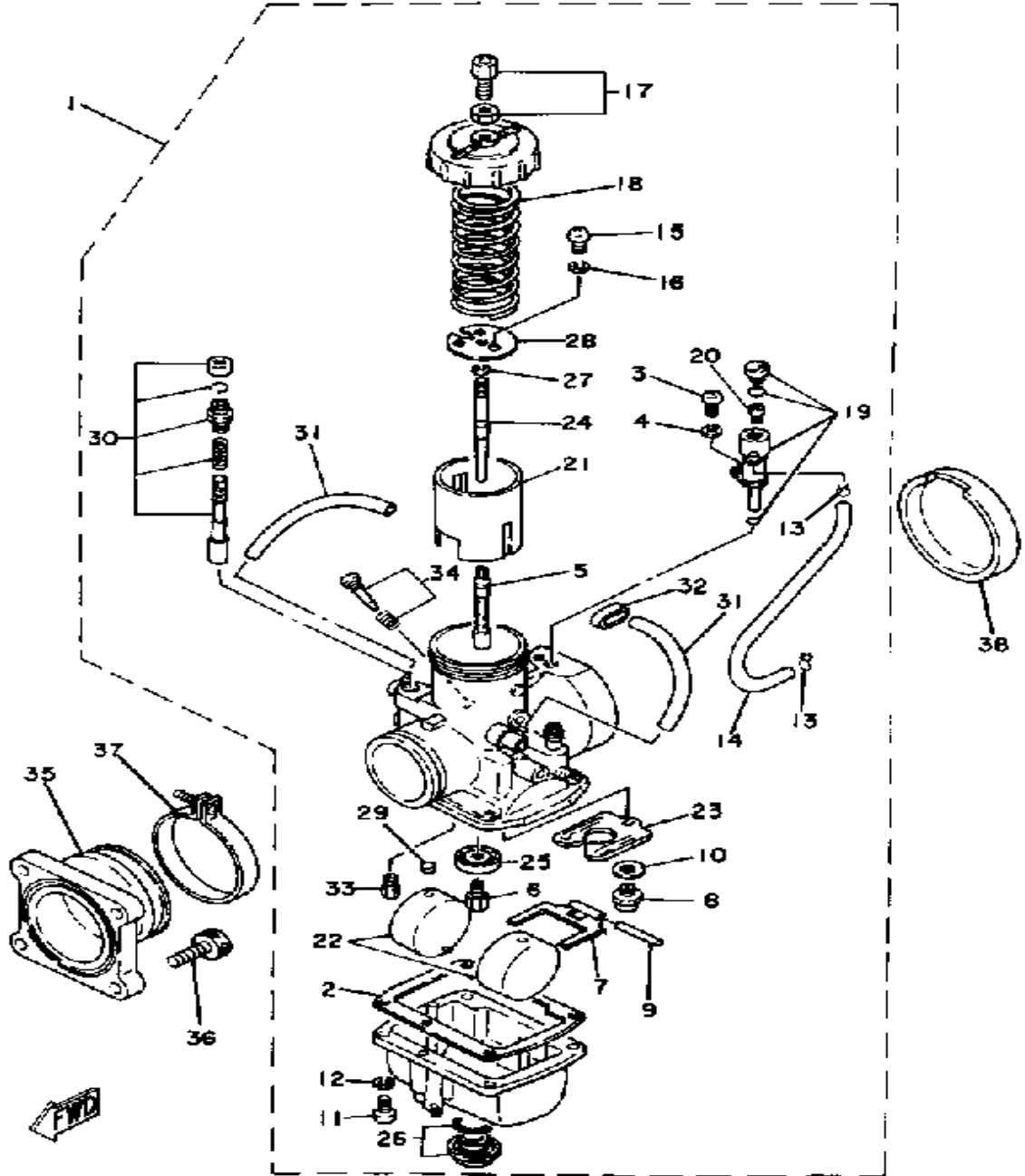

Ref. No.	Part Number	Description	Qty	Remarks
20	3G2-14231-14-00	. JET, PILOT AIR (#70)	1	U.R.
	3G2-14231-15-00	. JET, MAIN # 5	1	U.R.
	3G2-14231-16-00	. JET, MAIN #80 (#80)	1	U.R.
	3G2-14231-17-00	. JET, MAIN #85 (# 85)	1	U.R.
	3G2-14231-18-00	. JET, MAIN (# 90)	1	U.R.STD
21	(5F7-14112-00-00)	VALVE, THROTTLE 1	1	
22	214-14185-00-00	. FLOAT	2	
23	510-14146-00-00	. PLATE	1	
24	(275-14116-23-00)	NEEDLE	1	
25	(2X7-14194-00-00)	RING	1	
26	5F7-W1413-00-00	. PLUG SCREW SET	1	
27	164-14137-00-00	. CLIP	1	
28	3V3-14136-00-00	. SEAT, SPRING	1	
29	214-14118-00-00	. CAP	2	
30	26J-1410A-00-00	. STARTER SET	1	
31	310-14196-00-00	. PIPE, OVERFLOW	2	
32	(8F2-14139-00-00)	CLIP, PIPE	1	
33	193-14142-00-00	. JET, PILOT	1	
34	23X-14104-00-00	. AIR SCREW SET	1	
35	(5F7-13555-00-00)	MANIFOLD, INTAKE	2	
36	91316-06020-00	BOLT, SOCKET HEAD	8	
37	90460-49058-00	CLAMP, HOSE	2	
38	5F7-14157-01-00	COVER, MIXING	2	

EXHAUST

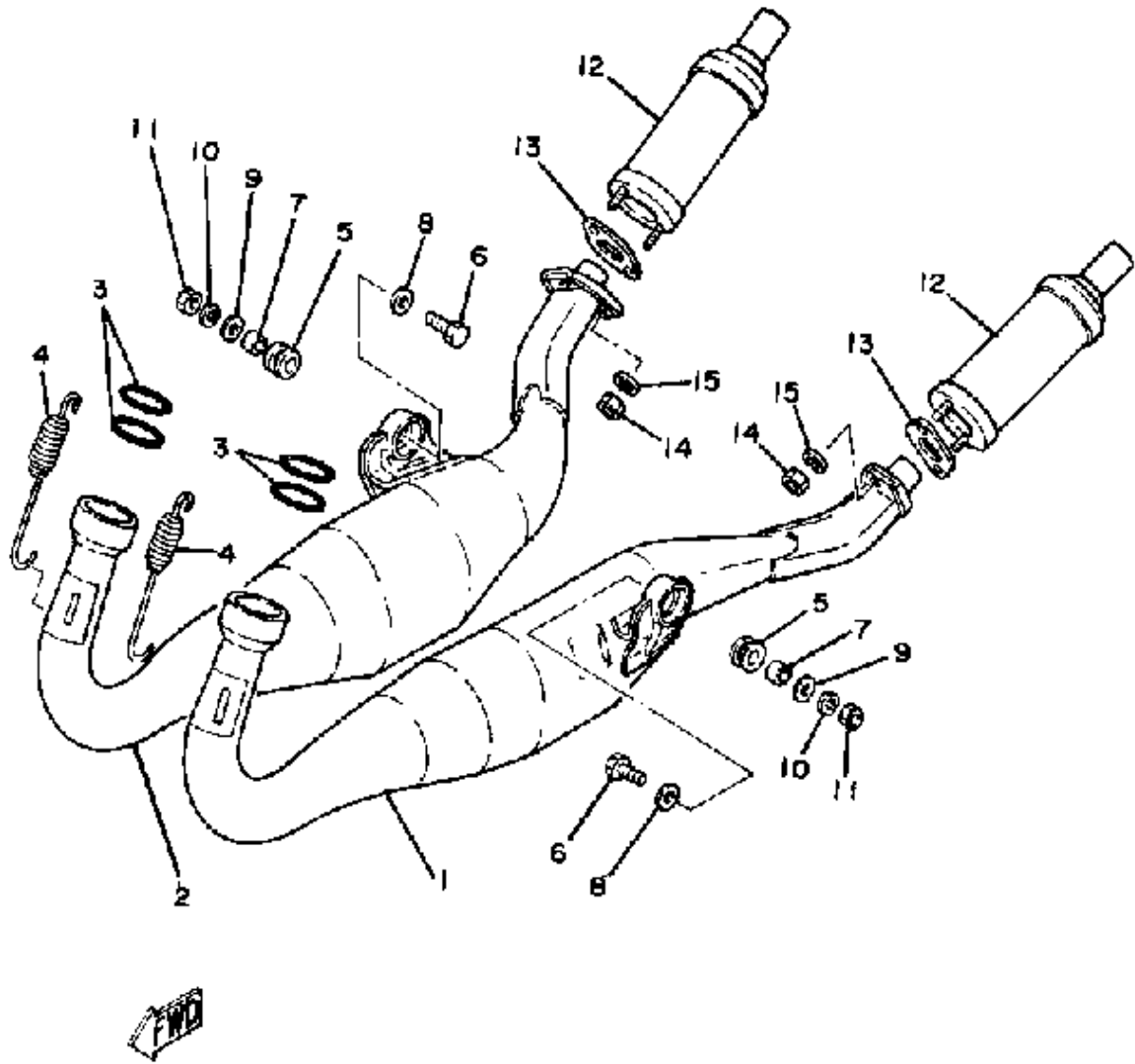

Ref. No.	Part Number	Description	Qty	Remarks
1	(5F7-14610-01-00)	EXHAUST PIPE ASSEMBLY L .	1	
2	(5F7-14620-01-00)	EXHAUST PIPE ASSEMBLY R .	1	
3	93210-41042-00	O-RING	4	
4	90507-20030-00	SPRING, TENSION	4	
5	565-14747-00-00	DAMPER, MUFFLER	2	
6	97313-08030-00	BOLT, HEXAGON	2	
7	90387-08258-00	COLLAR	2	
8	90201-08753-00	WASHER, PLATE	2	
9	92901-08600-00	WASHER	2	
10	92990-08100-00	WASHER	2	
11	95303-08700-00	NUT	2	
12	(5F7-14753-00-00)	SILENCER, EXHAUST	2	
13	3G2-14755-01-00	GASKET, SILENCER	2	
14	95611-06100-00	NUT, u	4	
15	92995-06100-00	WASHER, SPRING	4	

CRANKCASE

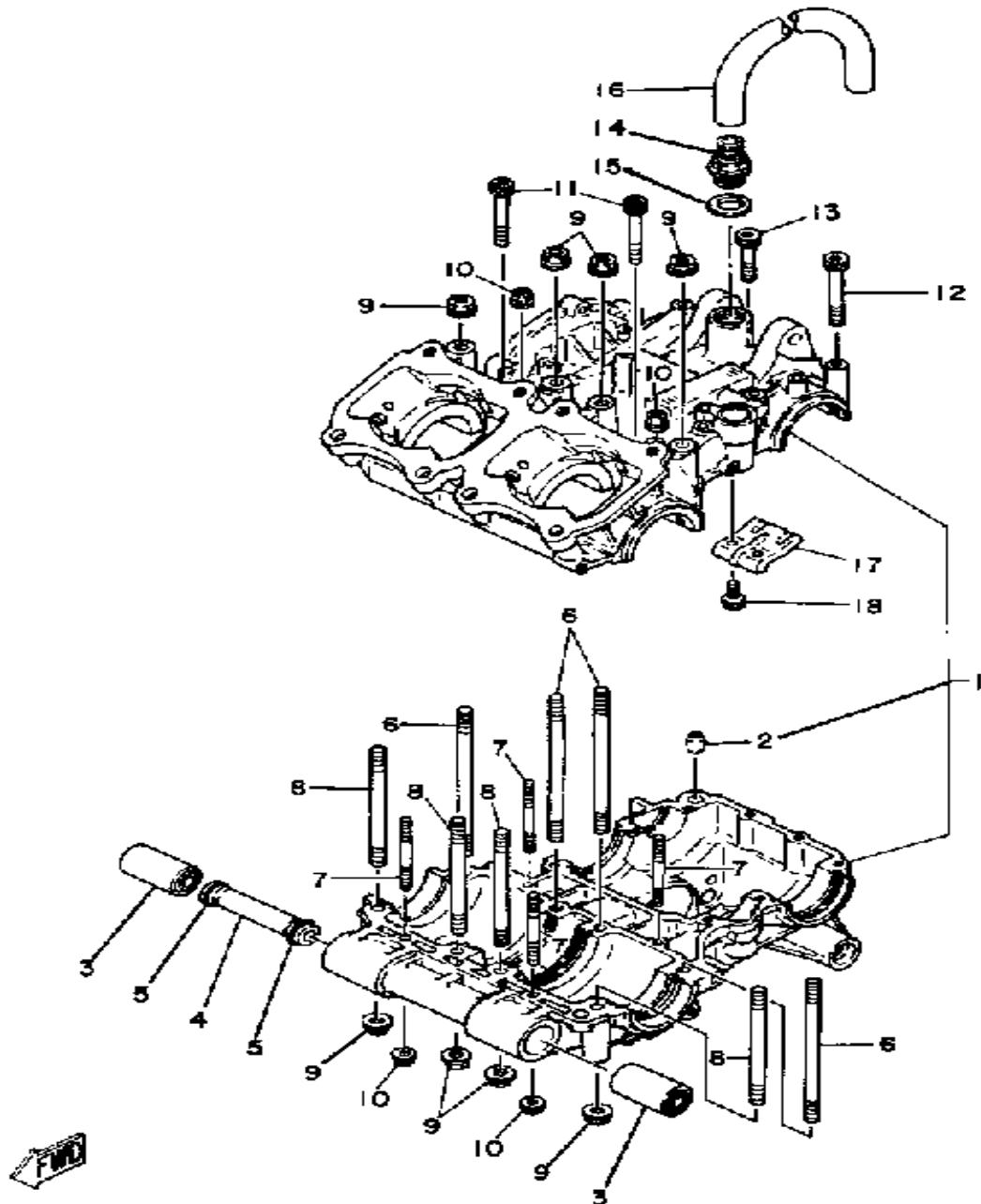

Ref. No.	Part Number	Description	Qty	Remarks
1	(5F7-15100-00-00)	CRANKCASE ASSEMBLY	1	
2	99530-10014-00	. PIN, DOWEL	2	
3	5F7-15316-01-00	DAMPER, ENG MT 1	2	
4	(5F7-15317-00-00)	SPACER, ENG MOUNT	1	
5	93210-16275-00	O-RING	2	
6	90116-08212-00	BOLT, STUD	4	
7	(90116-06341-00)	BOLT, STUD	4	
8	90116-08371-00	BOLT, STUD	4	
9	90179-08246-00	NUT, SPEC'L SHAPE	8	
10	90179-06009-00	NUT, SPEC'L SHAPE	8	
11	91316-06050-00	BOLT, SOCKET HEAD	2	
12	91316-06055-00	BOLT, SOCKET HEAD	6	
13	91316-06035-00	BOLT	2	
14	4A0-15371-00-00	BREATHER	1	
15	(4A0-15374-00-00)	GASKET, BREATHER	1	
16	(4A0-15373-00-00)	PIPE, BREATHER	1	
17	(5F7-11165-01-00)	PLATE, BREATHER	1	
18	91316-05012-00	BOLT	2	

CRANKCASE COVER

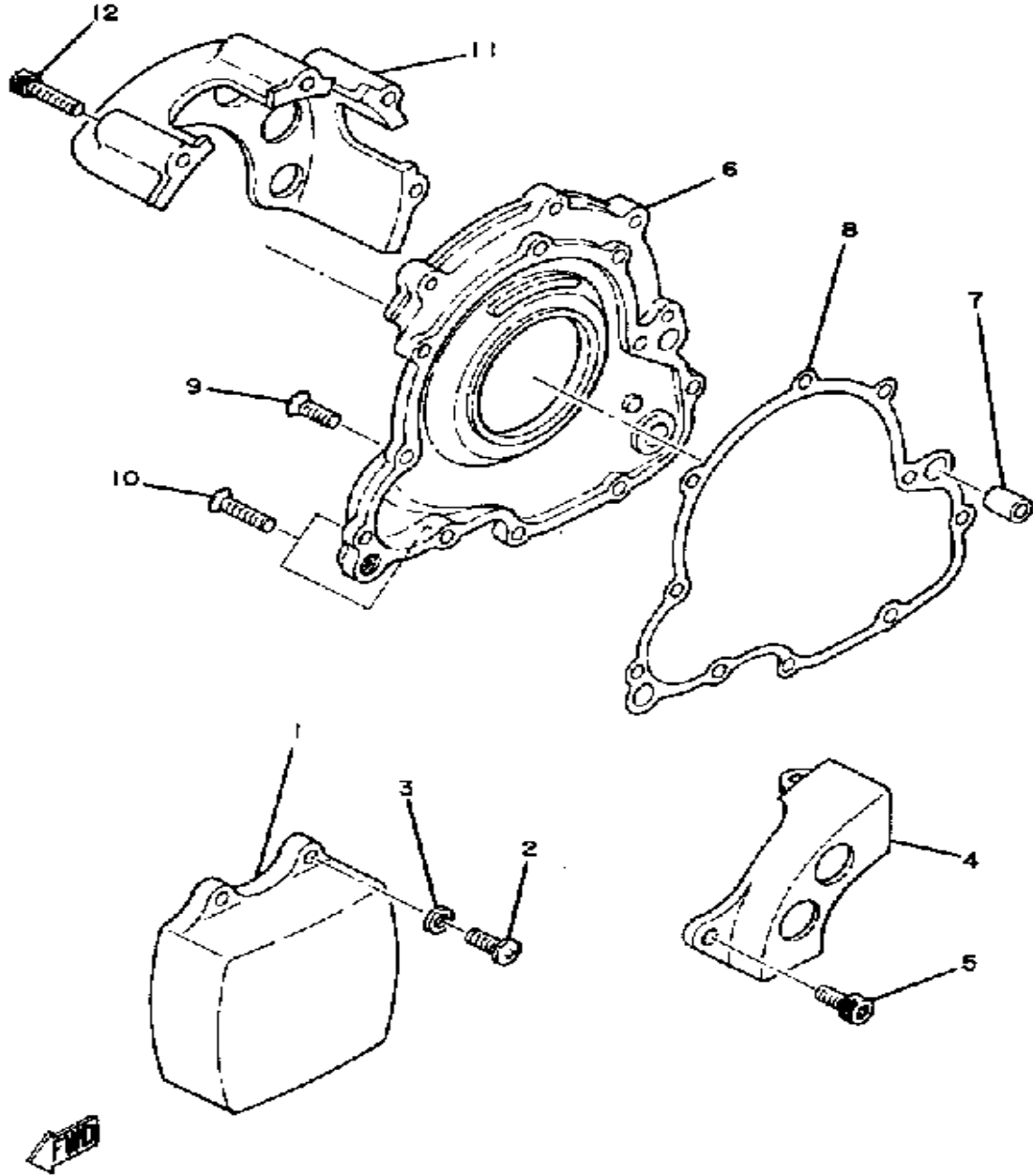

Ref. No.	Part Number	Description	Qty	Remarks
1	(5F7-15411-00-00)	COVER, CRANKCASE L	1	
2	98586-05016-00	SCREW, PAN HEAD	3	
3	92906-05600-00	WASHER, PLATE	3	
4	(5F7-15421-00-00)	COVER, CRANKCASE R	1	
5	91316-06012-00	BOLT, SOCKET HEAD	2	
6	(5F7-15431-00-00)	COVER, CRANKCASE 3	1	
7	99530-10014-00	PIN, DOWEL	2	
8	5F7-15462-00-00	GASKET, CRCS CVR 3	1	
9	90151-06010-00	SCREW, COUNTERSUNK	8	
10	98780-06025-00	SCREW, FLAT HEAD	2	
11	26J-15417-00-00	COVER, CAP	1	
12	91316-05050-00	BOLT, SOCKET HEAD	4	

CLUTCH

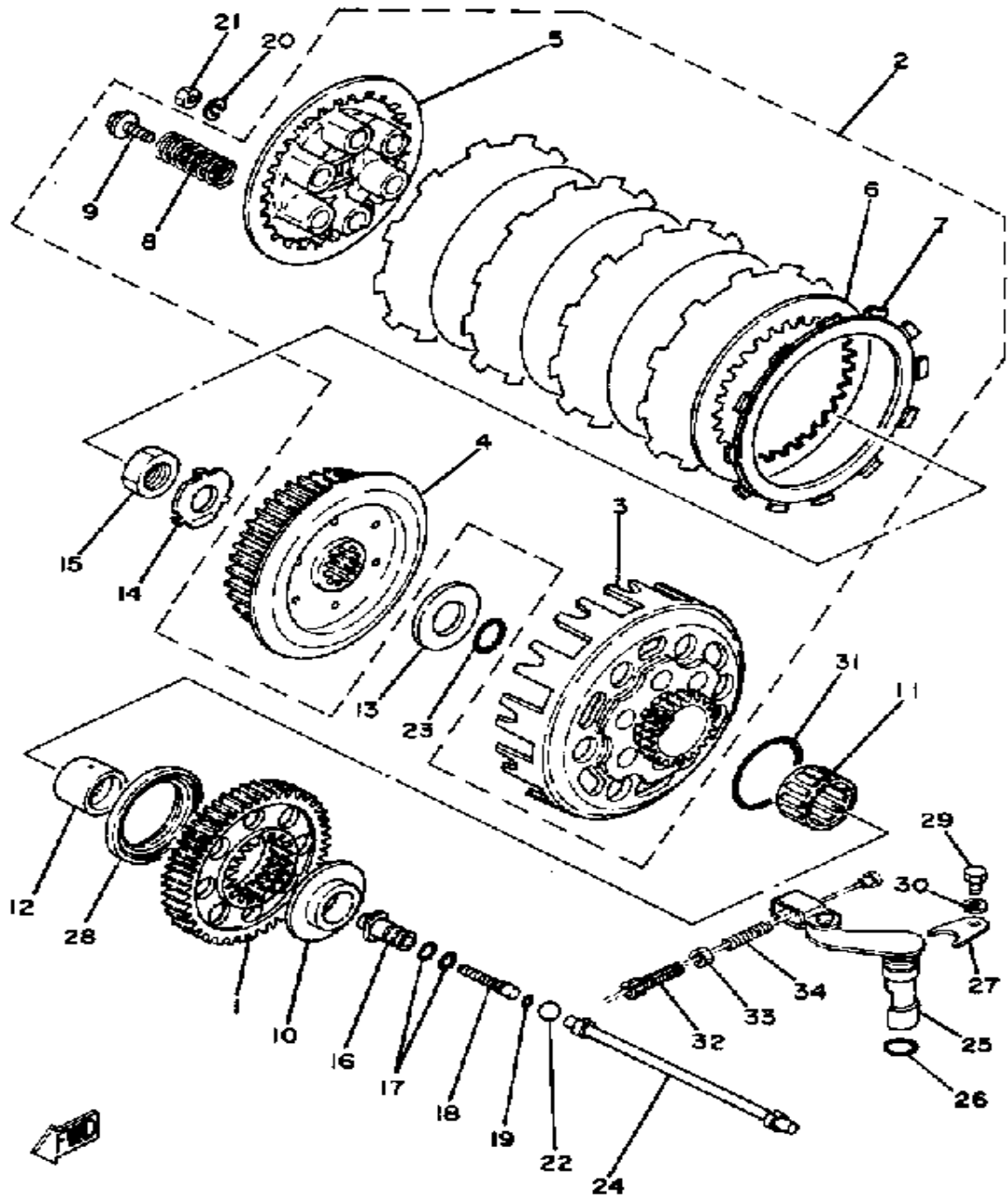

Ref. No.	Part Number	Description	Qty	Remarks
1	5F7-16151-00-00	GEAR, PRI DRIVEN	1	
2	(5F7-16300-00-00)	CLUTCH ASSEMBLY	1	
3	5F7-16310-00-00	. CLUTCH HOUSING ASSEMBLY	1	
4	5F7-16371-01-00	. BOSS, CLUTCH	1	
5	2K7-16351-00-00	. PLATE, PRESSURE 1	1	
6	4A0-16324-00-00	. PLATE, CLUTCH 1	5	
7	383-16321-10-00	. PLATE, FRICTION	5	
8	90501-23138-00	. SPRING, COMPRESSION	6	
9	90159-06016-00	. SCREW, WITH WASHER	6	
10	5F7-16154-00-00	PLATE, THRUST 1	1	
11	93310-332J5-00	BEARING	1	
12	5F7-16181-00-00	SPACER 1	1	
13	5F7-16153-00-00	WASHER, THRUST	1	
14	90215-20125-00	WASHER, LOCK	1	
15	90170-20255-00	NUT	1	
16	(5F7-16356-01-00)	ROD, PUSH 1	1	
17	93210-08006-00	O-RING	2	
18	5F7-16343-00-00	SCREW, ADJUSTING	1	
19	93210-04279-00	O-RING	2	
20	92995-06100-00	WASHER, SPRING	1	
21	95380-06600-00	NUT	1	
22	93515-32029-00	BALL	1	
23	93210-22298-00	O-RING	1	
24	5F7-16357-00-00	ROD, PUSH 2	1	
25	(5F7-16380-00-00)	PUSH LEVER ASSEMBLY	1	
26	93210-12790-00	O-RING	1	
27	5F7-16384-00-00	PLATE, SEAT	1	
28	93101-56095-00	OIL SEAL	1	

CONTINUED ON NEXT FRAME ►

CLUTCH

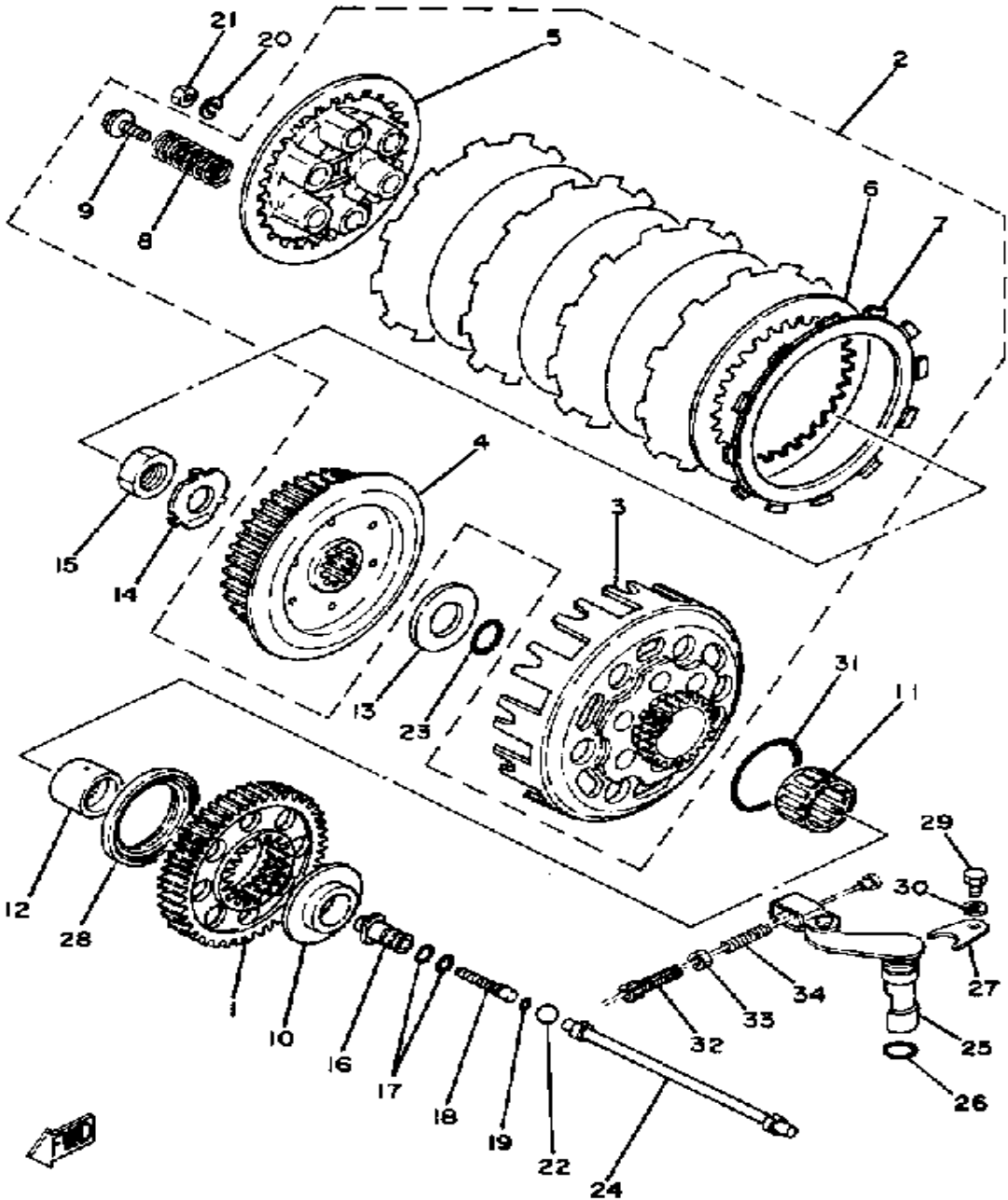

Ref. No.	Part Number	Description	Qty	Remarks
29	97313-05010-00	BOLT, HEXAGON	1	
30	92990-05100-00	WASHER, SPRING	1	
31	93210-42482-00	O-RING	1	
32	90123-06102-00	BOLT (59W)	1	
33	90179-06143-00	NUT, SPEC'L SHAPE	1	
34	90501-10075-00	SPRING, COMPRESSION	1	

TRANSMISSION

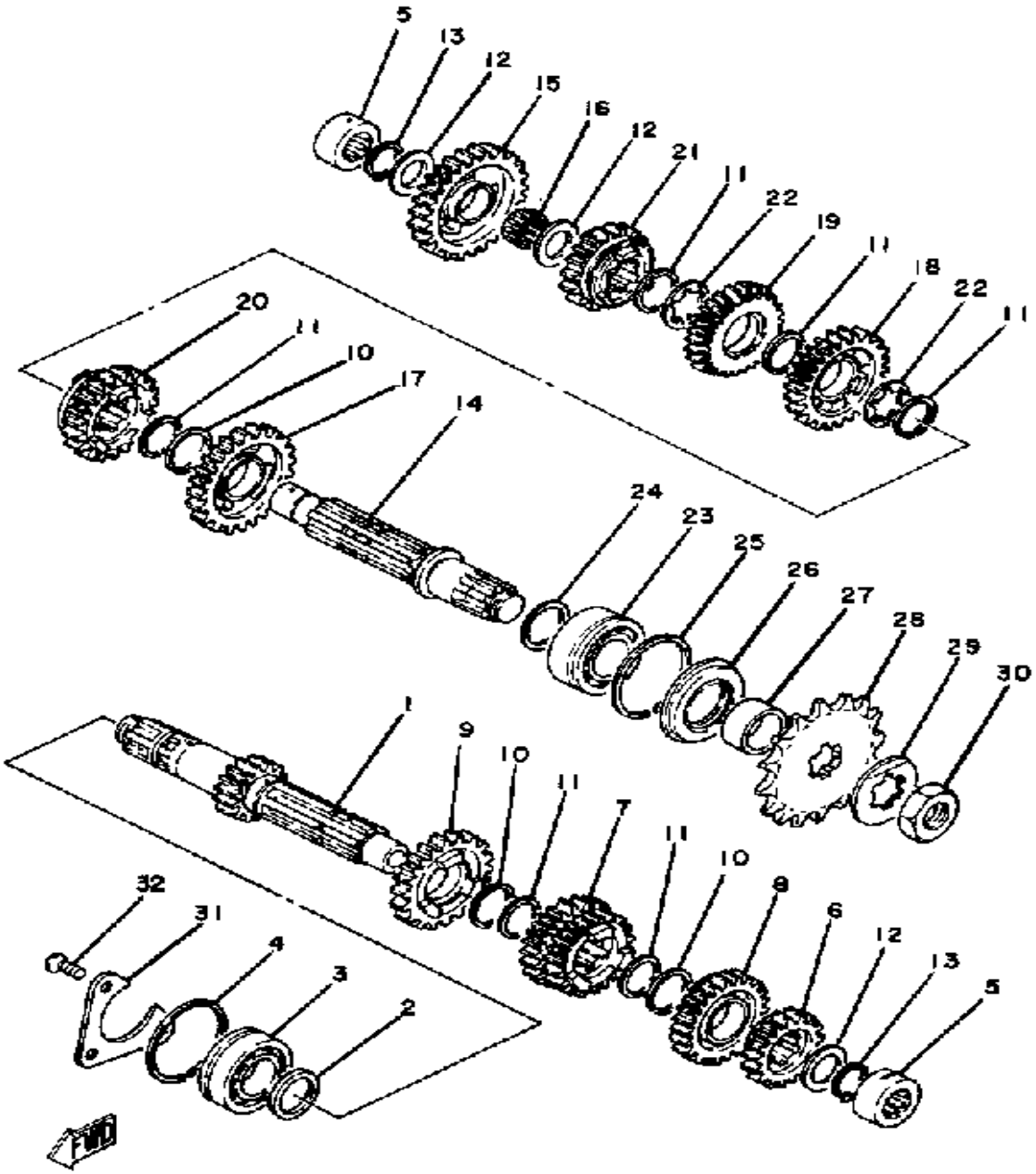

Ref. No.	Part Number	Description	Qty	Remarks
1	(5F7-17411-00-00)	AXLE, MAIN	1	
2	168-17428-01-03	SHIM 2 (25-34-0.3)	1	U.R.
	168-17428-01-05	SHIM 2 (25-34-0.5)	1	U.R.
3	93306-20546-00	BEARING	1	
4	93440-52009-00	CIRCLIP	1	
5	93311-62046-00	BEARING, CYLINDER.# 1	2	
6	5F7-17121-00-00	GEAR, 2ND PINION	1	
7	5F7-17131-00-00	GEAR, 3RD/4TH PINION (23T/25T)	1	
8	5F7-17151-01-00	GEAR, 5TH PINION (27T)	1	
9	5F7-17161-00-00	GEAR, 6TH PINION	1	
10	90201-253K0-00	WASHER, PLATE (T=1.0)	3	
11	93440-25084-00	CIRCLIP	6	
12	90201-20276-00	WASHER, PLATE (1.0T)	3	
13	99009-20400-00	CIRCLIP	2	
14	5F7-17421-00-00	AXLE, DRIVE	1	
15	99999-02246-00	GEAR, 1ST WHEEL	1	
16	93310-22057-00	BEARING (K20-24X10 S)	1	
17	5F7-17221-00-00	GEAR, 2ND WHEEL	1	
18	5F7-17231-00-00	GEAR, 3RD WHEEL (29T)	1	
19	5F7-17241-00-00	GEAR, 4TH WHEEL	1	
20	5F7-17251-01-00	GEAR, 5TH WHEEL	1	
21	5F7-17261-01-00	GEAR, 6TH WHEEL	1	
22	5F7-17136-00-00	WASHER (0.7T)	2	
	90209-22082-00	WASHER (0.5T)	2	U.R.
23	93305-20504-00	BEARING	1	
24	168-17428-01-03	SHIM 2 (25-34-0.3)	1	U.R.
	168-17428-01-05	SHIM 2 (25-34-0.5)	1	U.R.
25	93440-52014-00	CIRCLIP	1	

CONTINUED ON NEXT FRAME ►

TRANSMISSION

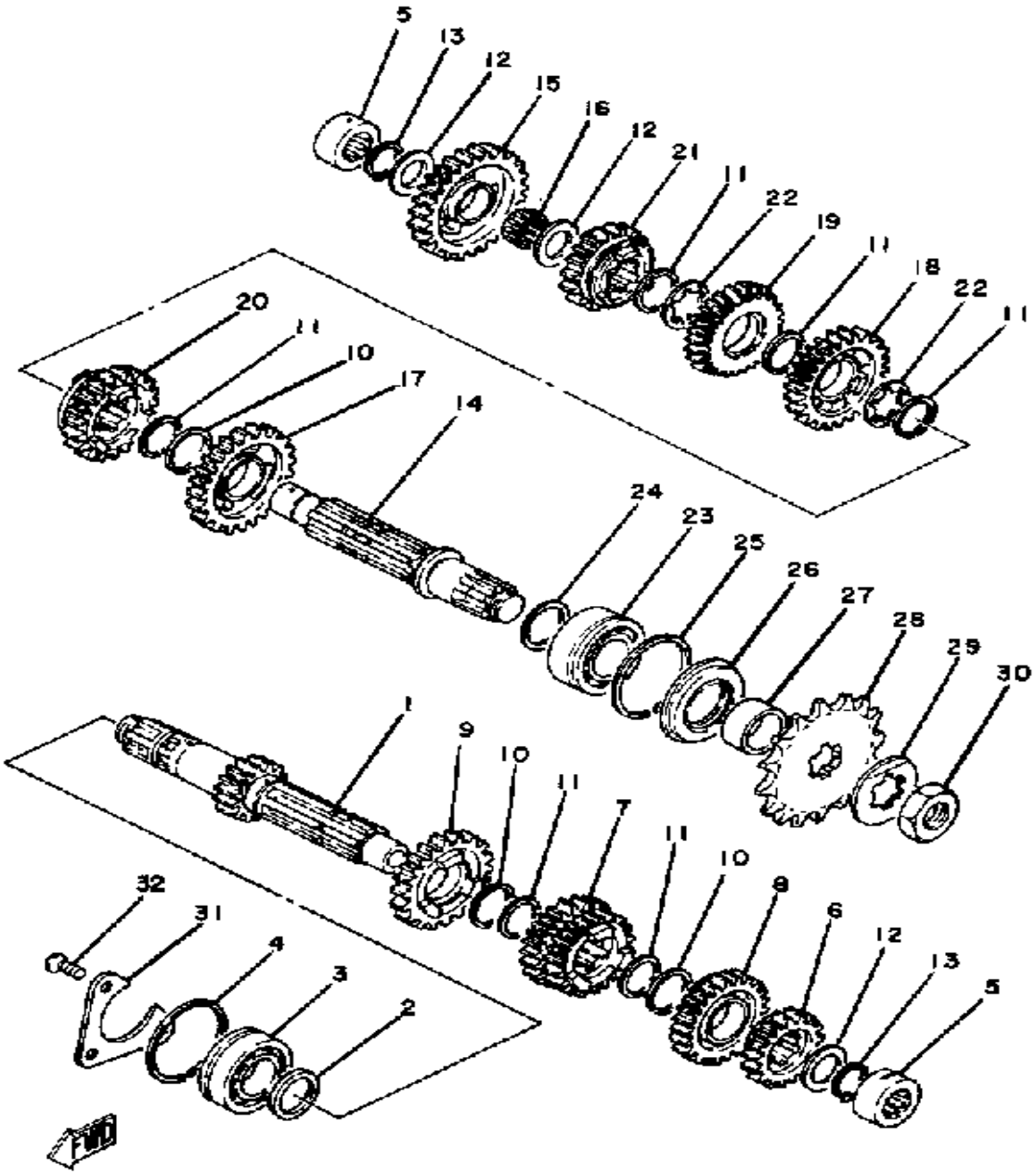

Ref. No.	Part Number	Description	Qty	Remarks
26	93102-32246-00	OIL SEAL, SD-TYPE	1	
27	(90387-254E9-00)	COLLAR	1	
28	(5F7-17461-50-00)	SPROCKET, DRIVE	1	
	(5F7-17461-60-00)	SPROCKET, DRIVE	1	
	(5F7-17461-70-00)	SPROCKET, DRIVE	1	
	93834-18135-00	SPROCKET, DRIVE	1	
29	90215-21239-00	WASHER, LOCK	1	
30	90179-20255-00	NUT	1	
31	(5F7-15381-00-00)	PLATE, BRNG COVER	1	
32	98603-06012-00	SCREW, OVAL HEAD (92701-06012)	3	

SHIFT CAM - FORK

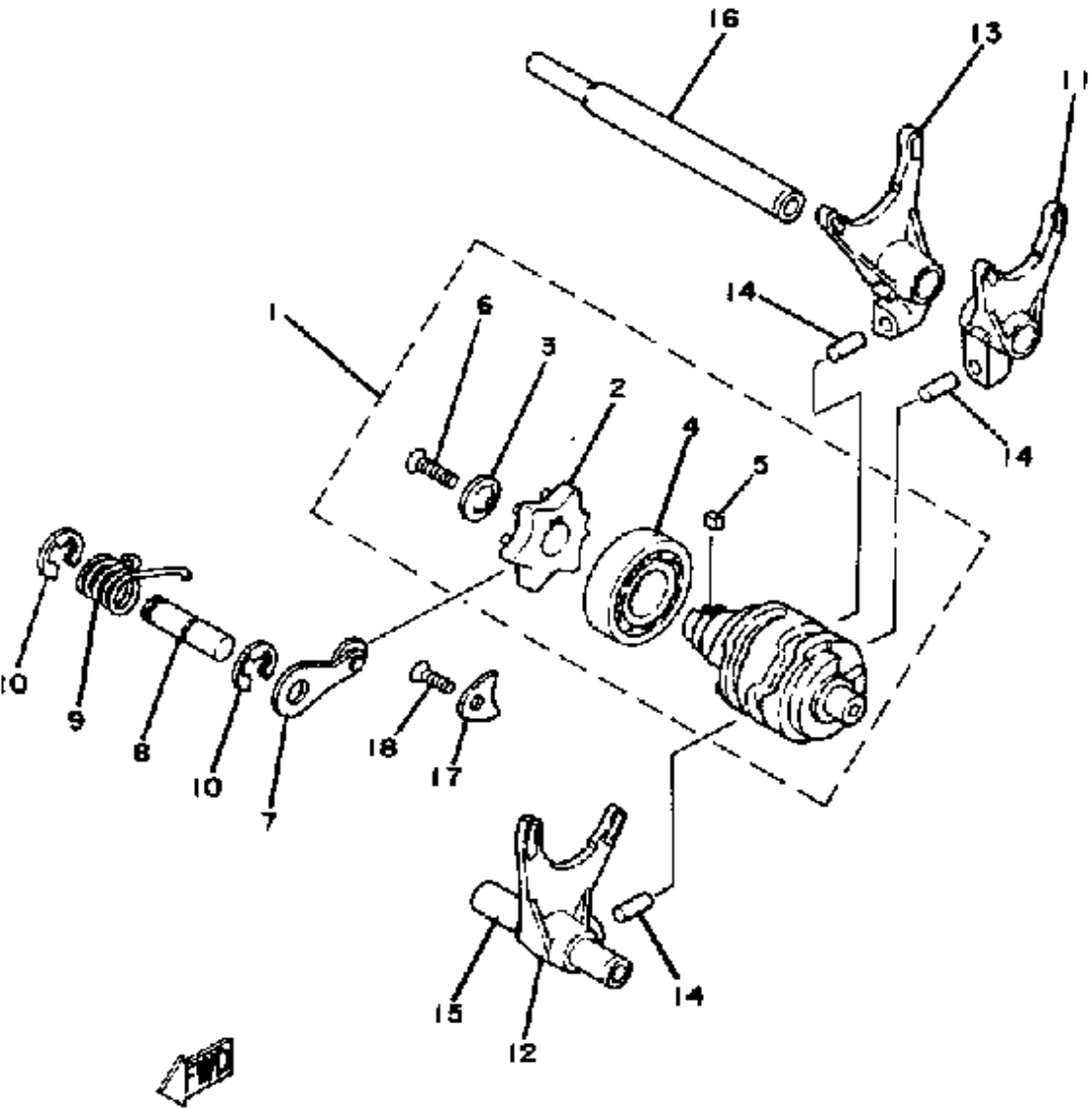

Ref. No.	Part Number	Description	Qty	Remarks
1	59W-18540-00-00	SHIFT CAM ASSEMBLY	1	
2	3R4-18185-00-00	. SEGMENT	1	
3	3R4-18561-00-00	. PLATE, SIDE 1	1	
4	93306-00435-00	. BEARING	1	
5	90282-04036-00	. KEY, STRAIGHT	1	
6	98701-05016-00	. SCREW, FLAT HEAD	1	
7	5F7-18140-00-00	STOPPER LEVER ASSEMBLY	1	
8	(5F7-18197-00-00)	SHAFT	1	
9	90508-26489-00	SPRING, TORSION	1	
10	93430-08007-00	CIRCLIP	2	
11	3AK-18511-00-00	FORK, SHIFT 1	1	
12	5F7-18512-00-00	FORK, SHIFT 2	1	
13	3AK-18513-00-00	FORK, SHIFT 3	1	
14	93606-14154-00	PIN, DOWEL	3	
15	5F7-18531-00-00	BAR, SHIF FRK GDE 1	1	
16	(5F7-18535-00-00)	BAR, SHIF FRK GDE 2	1	
17	(5F7-18141-00-00)	PLATE, STOPPER	2	
18	98603-06012-00	SCREW, OVAL HEAD (92701-06012)	2	

SHIFT SHAFT - PEDAL

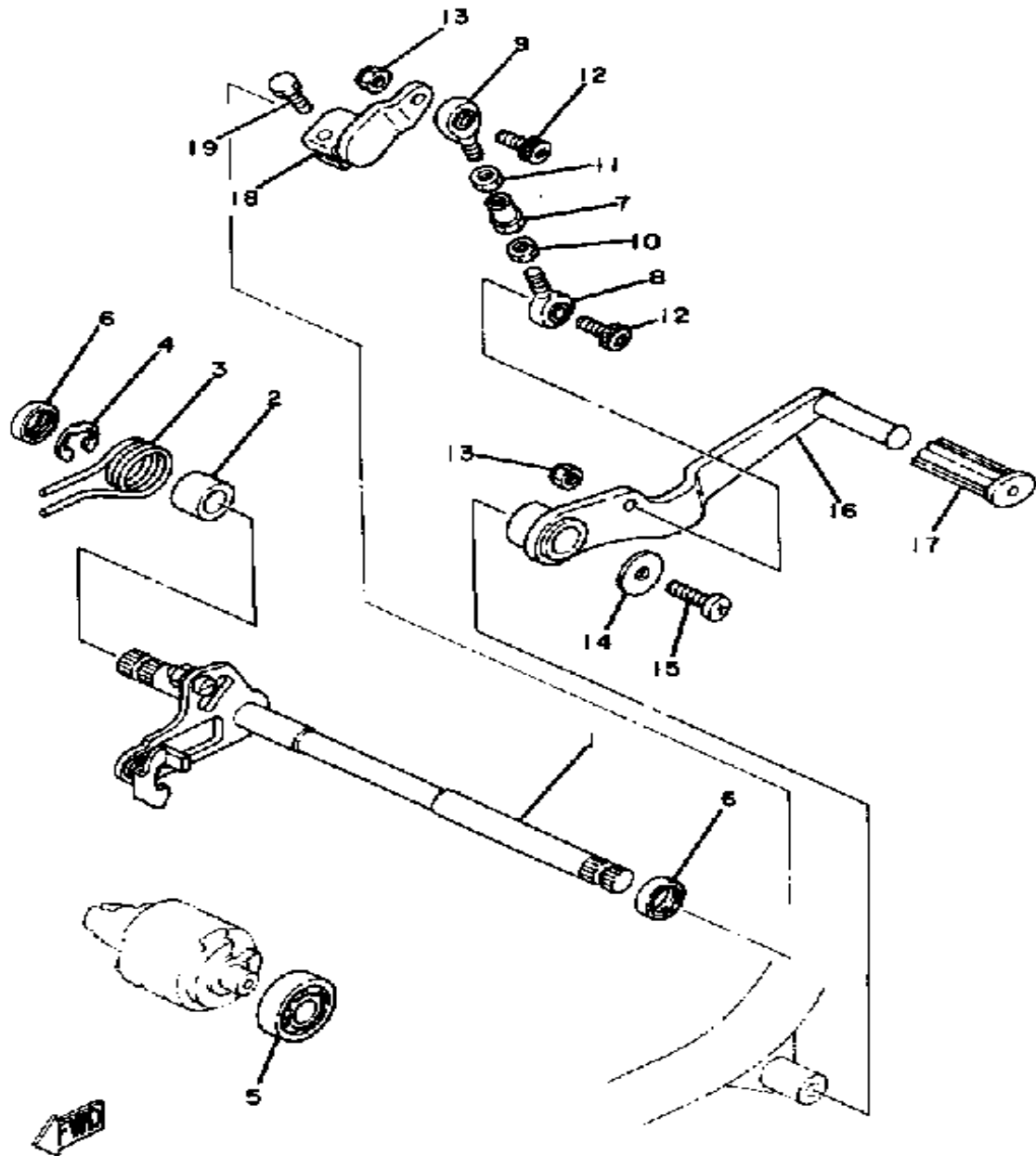

Ref. No.	Part Number	Description	Qty	Remarks
1	(26J-18101-00-00)	SHIFT SHAFT ASSEMBLY 1	1	
2	90560-12171-00	SPACER	1	
3	90508-32318-00	SPRING, TORSION	1	
4	99006-10600-00	CIRCLIP	1	
5	93306-20110-00	BEARING (B6201)	1	
6	93109-12012-00	OIL SEAL	2	
7	5F7-18115-00-00	ROD, SHIFT	1	
8	5F7-18116-00-00	JOINT, ROD 1	1	
9	5F7-18117-00-00	JOINT, ROD 2	1	
10	95380-06700-00	NUT	1	
11	90170-06228-00	NUT (COUNTER CLOCKWISE)	1	
12	92016-06020-00	SCREW	2	
13	95601-06100-00	NUT, U	2	
14	90201-063J2-00	WASHER, PLATE	1	
15	92011-06014-00	BOLT, BUTTON HEAD	1	
16	5F7-18111-00-00	PEDAL, SHIFT	1	
17	240-18113-00-00	COVER, SHIFT PEDAL	1	
18	5F7-18112-00-00	ARM, SHIFT	1	
19	97011-06020-00	BOLT	1	

FRAME

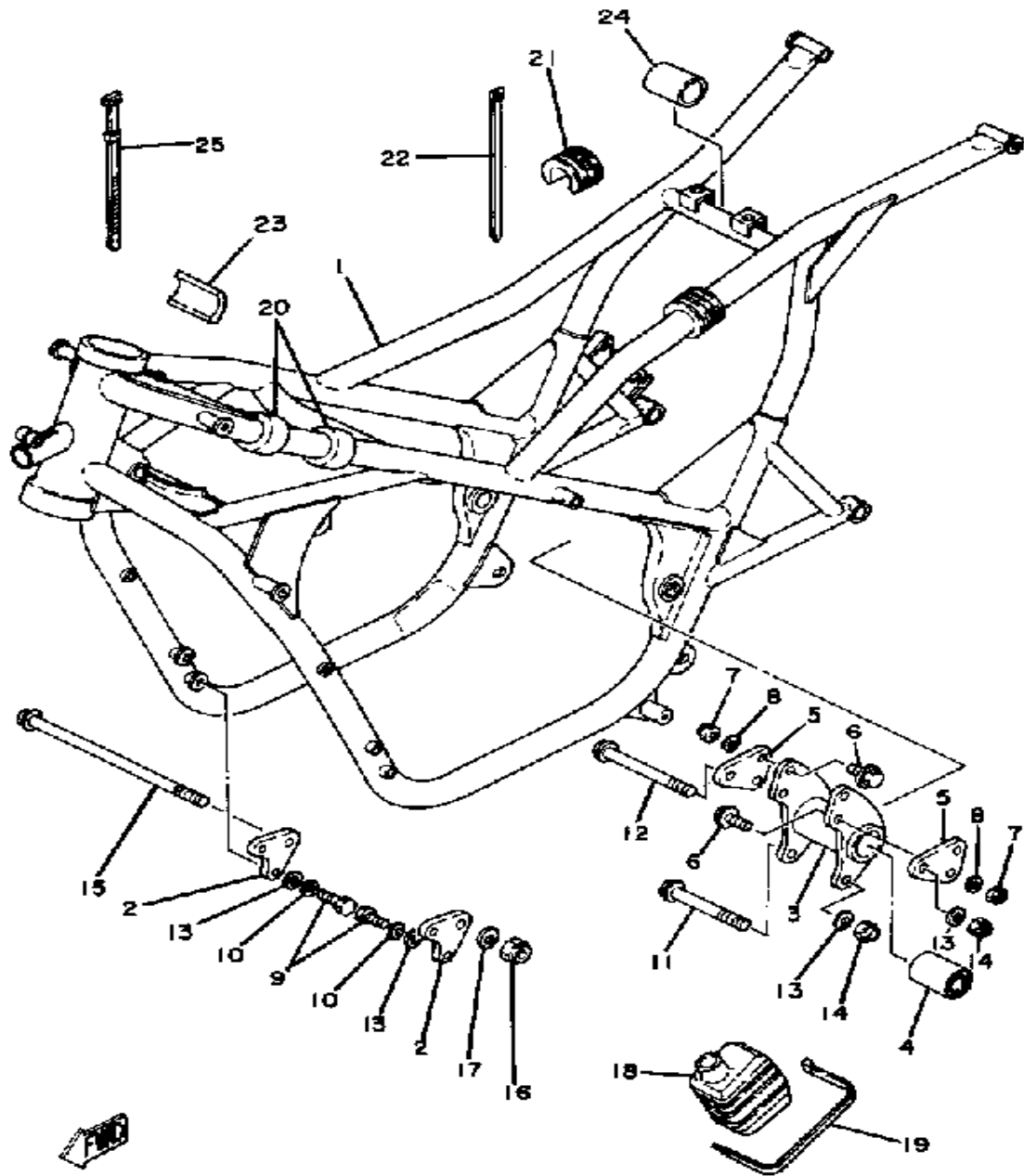

Ref. No.	Part Number	Description	Qty	Remarks
1	(5F7-21110-00-33)	FRAME	1	
2	5F7-21411-00-00	BRACKET, ENGINE 1	2	
3	(5F7-21419-00-00)	BRACKET, ENGINE 2	1	
4	(5F7-2139X-00-00)	DAMPER	2	
5	(5F7-21429-00-00)	BRACKET, ENGINE 3	2	
6	95811-06020-00	BOLT, FLANGE	4	
7	95601-06100-00	NUT, U	4	
8	92990-06200-00	WASHER	4	
9	97013-08025-00	BOLT	4	
10	92990-08100-00	WASHER	4	
11	90105-08064-00	BOLT, WASHER BASED	1	
12	90105-08100-00	BOLT, WASHER BASED	1	
13	92901-08600-00	WASHER	6	
14	95611-08100-00	NUT, U	2	
15	90105-10113-00	BOLT, WASHER BASED	1	
16	95601-10100-00	NUT, U (95602-10100-00)	1	
17	92990-10200-00	WASHER, PLAIN	1	
18	4A0-21751-00-00	TANK, OIL	2	
19	90464-14117-00	CLAMP	4	
20	1J7-24183-02-00	DAMPER, LOCATING 3	4	
21	5F6-24181-00-00	DAMPER, LOCATING 1	2	
22	90465-13169-00	CALMP	6	
23	240-24181-00-00	DAMPER, LOCATING 1	1	
24	3G2-24182-00-00	DAMPER, LOCATING 2	1	
25	437-83936-01-00	BAND, SWITCH CORD	4	

FRONT FENDER - REAR FENDER

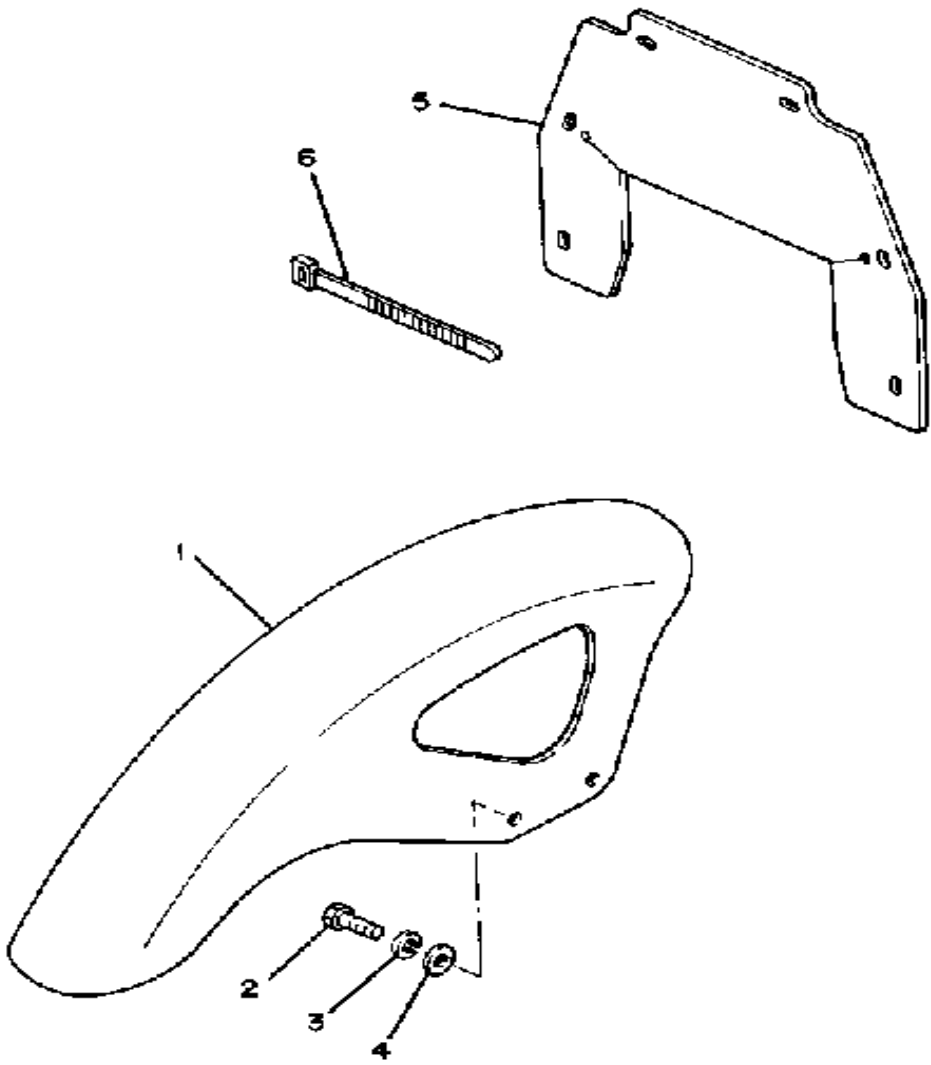

Ref. No.	Part Number	Description	Qty	Remarks
1	(5F7-21511-00-E1)	FENDER, FRONT	1	
2	97313-06016-00	BOLT, HEXAGON	4	
3	92995-06100-00	WASHER, SPRING	4	
4	92901-06600-00	WASHER	4	
5	5F7-21611-00-00	FENDER, REAR	1	
6	437-83936-01-00	BAND, SWITCH CORD	6	



REAR ARM

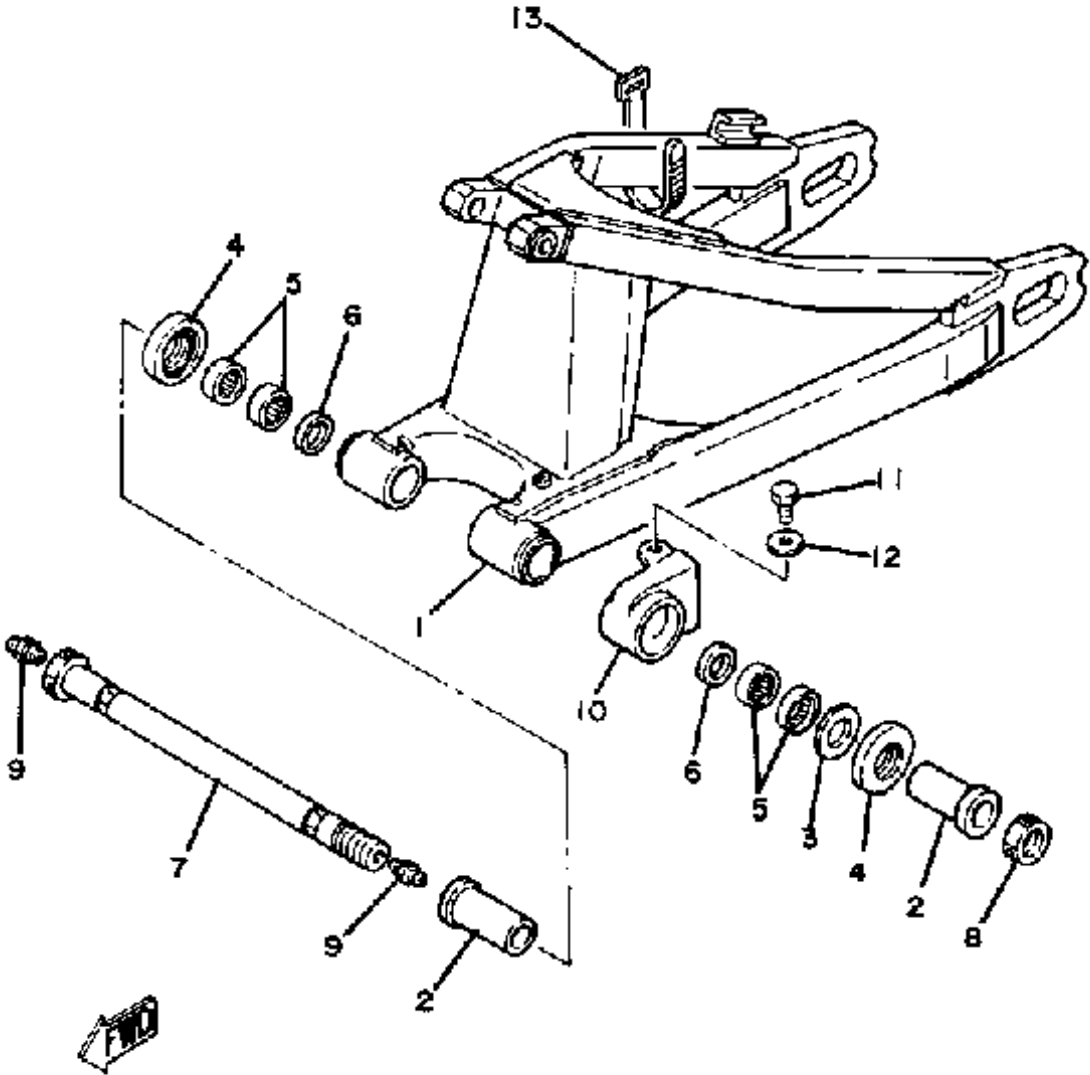

Ref. No.	Part Number	Description	Qty	Remarks
1	(5F7-22110-00-00)	REAR ARM	1	
2	(5F7-22124-00-00)	BUSH 2	2	
3	648-45533-00-02	SHIM (90201-22284)	1	U.R.
	648-45533-00-03	SHIM	1	U.R.
4	93342-22205-00	BEARING, FLAT # 2	2	
5	93317-22214-00	BEARING, CYLINDER.# 7	4	
6	93109-22018-00	OIL SEAL, SDO-TYPE	2	
7	(1H3-22141-00-00)	SHAFT, PIVOT	1	
8	90179-16028-00	NUT, SPEC'L SHAPE	1	
9	93700-06M03-00	NIPPLE, GREASE	2	
10	5F7-22151-00-00	SEAL, GUARD	1	
11	97013-06012-00	BOLT	2	
12	90209-06064-00	WASHER, SPEC'L SHAP (812-82327-00) 0 1	2	
13	437-83936-11-00	BAND, SWITCH CORD	1	

REAR SUSPENSION

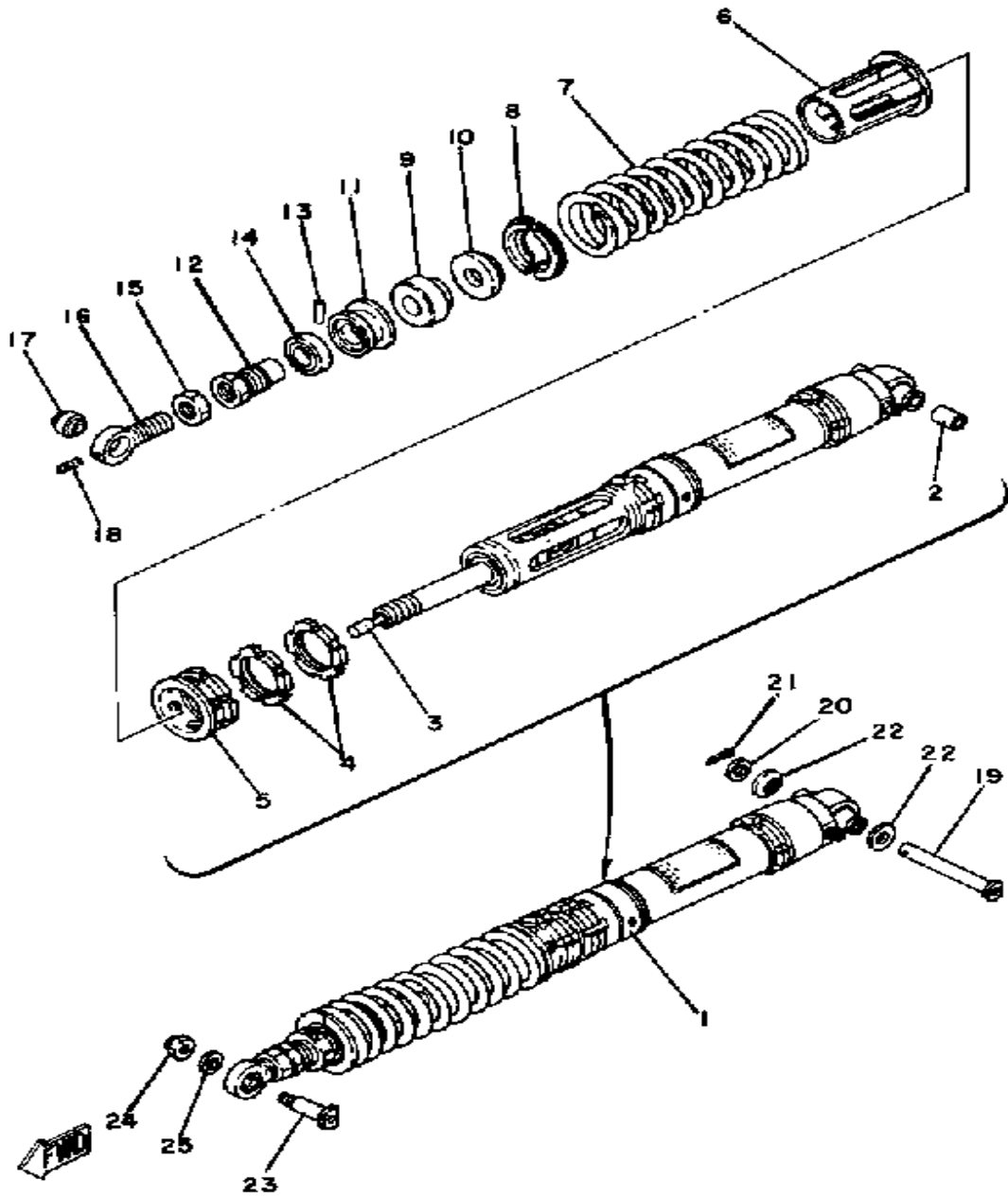

Ref. No.	Part Number	Description	Qty	Remarks
1	(5F7-22210-01-00)	SHK/ABS ASSEMBLY, REAR	1	
2	90380-12051-00	. BUSH, SOLID	2	
3	(5A0-W2227-00-00)	PUSH ROD SET	1	
4	(5A0-22215-00-00)	RING, COVER	2	
5	(5A0-22223-00-00)	SEAT, SPRING LOWER	1	
6	(5A0-22224-00-00)	GUIDE, SPRING 2	1	
7	(5F7-22212-00-00)	SPRING	1	
8	(5A0-22214-00-00)	GUIDE, SPRING 1	2	
9	(5F7-22493-00-00)	BUMP, STOP	1	
10	(5A0-22472-00-00)	CAP, CASE	1	
11	(5A0-22213-00-00)	SEAT, SPRING UPPER	1	
12	(5A0-22491-00-00)	ROD, EXTENSION	1	
13	93604-30173-00	. PIN, DOWEL	1	
14	(5A0-W2228-00-00)	ADJUST NUT SET	1	
15	(90170-18288-00)	NUT, HEXAGON	1	
16	(5F7-22219-00-00)	BRACKET, UPPER	1	
17	93399-99901-00	. BEARING	1	
18	(90113-02044-00)	BOLT, SET	1	
19	90240-12086-00	PIN, CLEVIS	1	
20	90201-12166-00	WASHER, PLATE	1	
21	91401-30030-00	PIN, COTTER	1	
22	1W1-22128-00-00	COVER, THRUST 1	2	
23	4A0-22242-00-00	BOLT 2	1	
24	95712-08300-00	NUT, LOCK	1	
25	92990-08200-00	WASHER, PLAIN	1	

STEERING

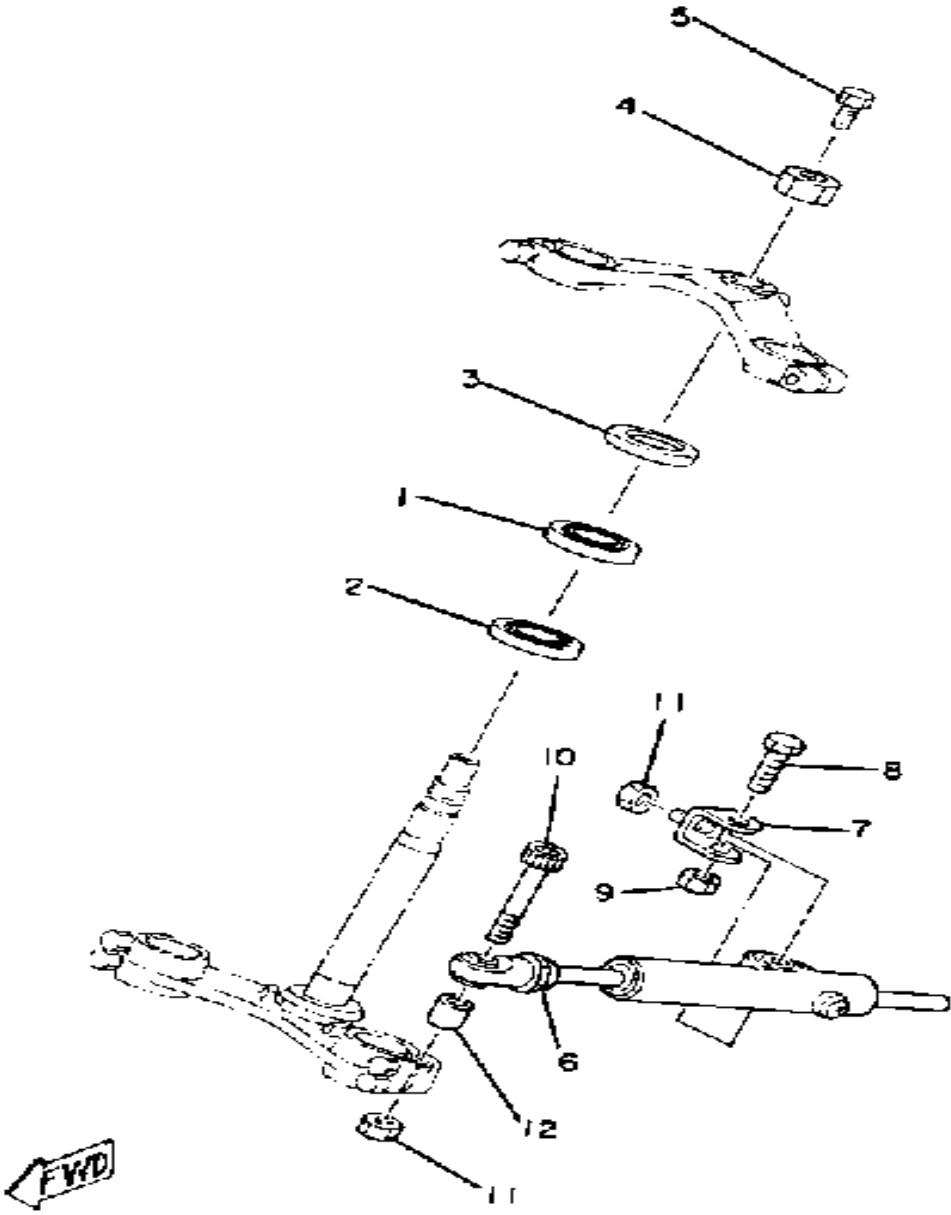

Ref. No.	Part Number	Description	Qty	Remarks
1	93332-00001-00	BEARING	1	
2	93332-00008-00	BEARING	1	
3	1J7-23415-00-00	COVER, BALL RACE 1	1	
4	90179-25033-00	NUT	1	
5	90105-14102-00	BOLT, WASHER BASED	1	
6	49V-23490-00-00	HDLBR SMY DMPR ASSEMBLY	1	
7	59W-23491-00-00	JOINT	1	
8	97313-08030-00	BOLT, HEXAGON	1	
9	95303-08700-00	NUT	1	
10	91316-08045-00	BOLT, SOCKET HEAD	1	
11	95611-08100-00	NUT, U	2	
12	90387-081A5-00	COLLAR	1	

FRONT FORK

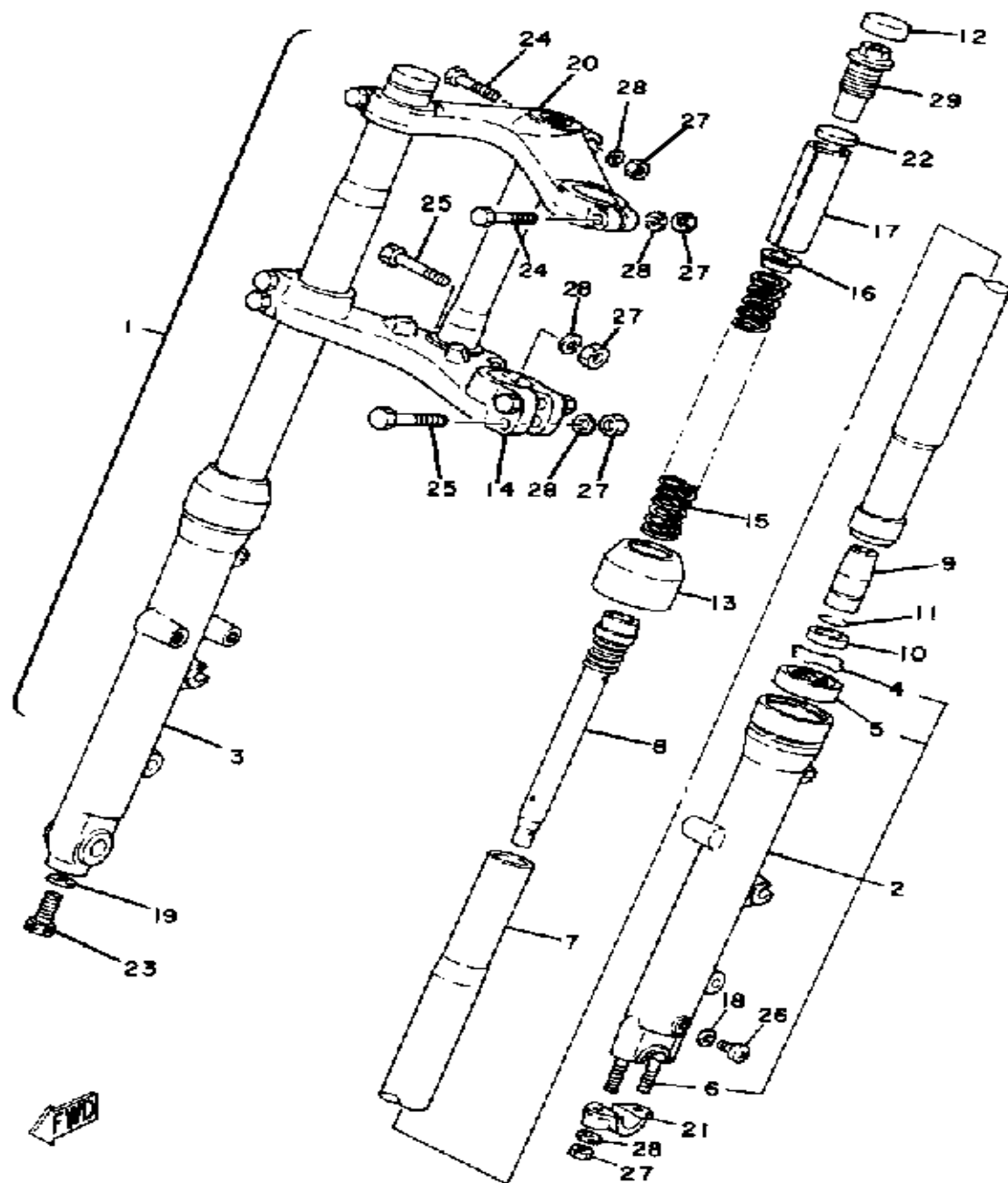

Ref. No.	Part Number	Description	Qty	Remarks
1	(5F7-23101-00-00)	FRONT FORK ASSEMBLY	1	
2	(5F7-23126-00-00)	TUBE, OUTER 1	1	
3	(5F7-23136-00-00)	TUBE, OUTER 2	1	
4	4A1-23156-00-00	.. CLIP, OIL SEAL	2	
5	49A-23145-00-00	.. OIL SEAL (15R-23145-00)	2	
6	90116-08261-00	.. BOLT, STUD	2	
7	(5F7-23124-00-00)	TUBE, INNER 1	2	
8	(5F7-23170-00-00)	CYLINDER, FRTRFK	2	
9	(3G2-23173-00-00)	SPINDLE, TAPER	2	
10	(3G2-23184-00-00)	CAP, AIR VALVE	2	
11	(3G2-23183-00-00)	CIRCLIP	2	
12	2F0-23168-00-00	. CAP, FRONT FORK	2	
13	583-23144-00-00	. SEAL, DUST	2	
14	(5F7-23340-00-00)	UNDER BRACKET	1	
15	(5F7-23141-00-00)	SPRING, FRONT FORK	2	
16	583-23142-00-00	. SEAT, SPRING UPPER	2	
17	11H-23118-00-00	. SPACER	2	
18	122-23129-00-00	. GASKET, DRAIN PLUG	2	
19	509-23158-L0-00	. GASKET	2	
20	(1H3-23435-00-00)	CROWN, HANDLE	1	
21	341-23167-50-00	. HOLDER, AXLE	1	
22	2H7-23149-00-00	. WASHER, SPRING UPR	2	
23	278-23181-50-00	. BOLT, HEXAGON SOCKET HEAD	2	
24	90101-08263-00	. BOLT	3	
25	5F7-23346-00-00	. BOLT 1	4	
26	4H7-23119-00-00	. PLUG, DRAIN - (122-23119-01)	2	
27	90185-08089-00	. NUT, SELF-LOCKING	9	
28	92901-08600-00	. WASHER	9	

CONTINUED ON NEXT FRAME ►

FRONT FORK

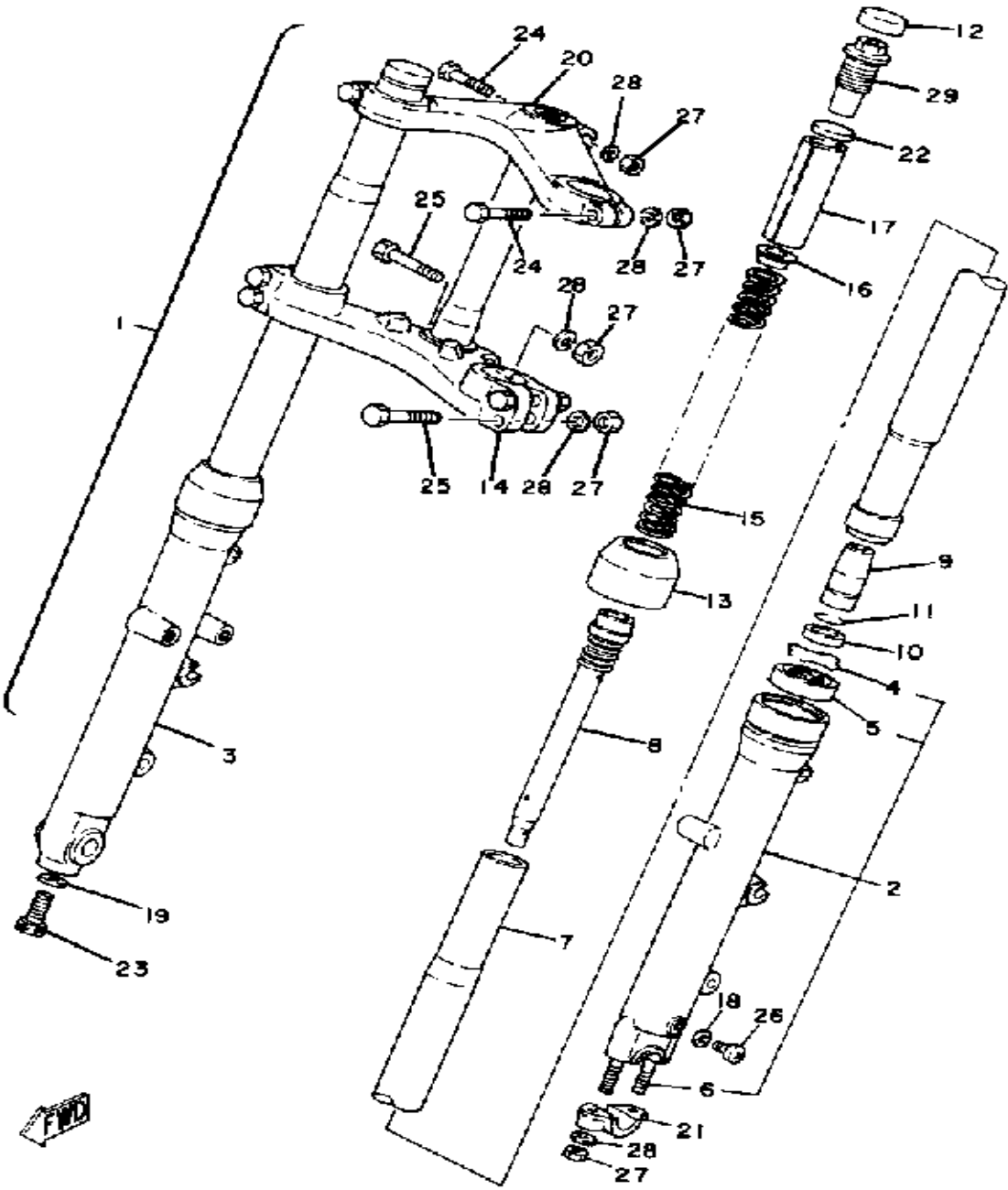

Ref. No.	Part Number	Description	Qty	Remarks
29	(5F7-23111-00-00)	BOLT, CAP	2	

FUEL TANK

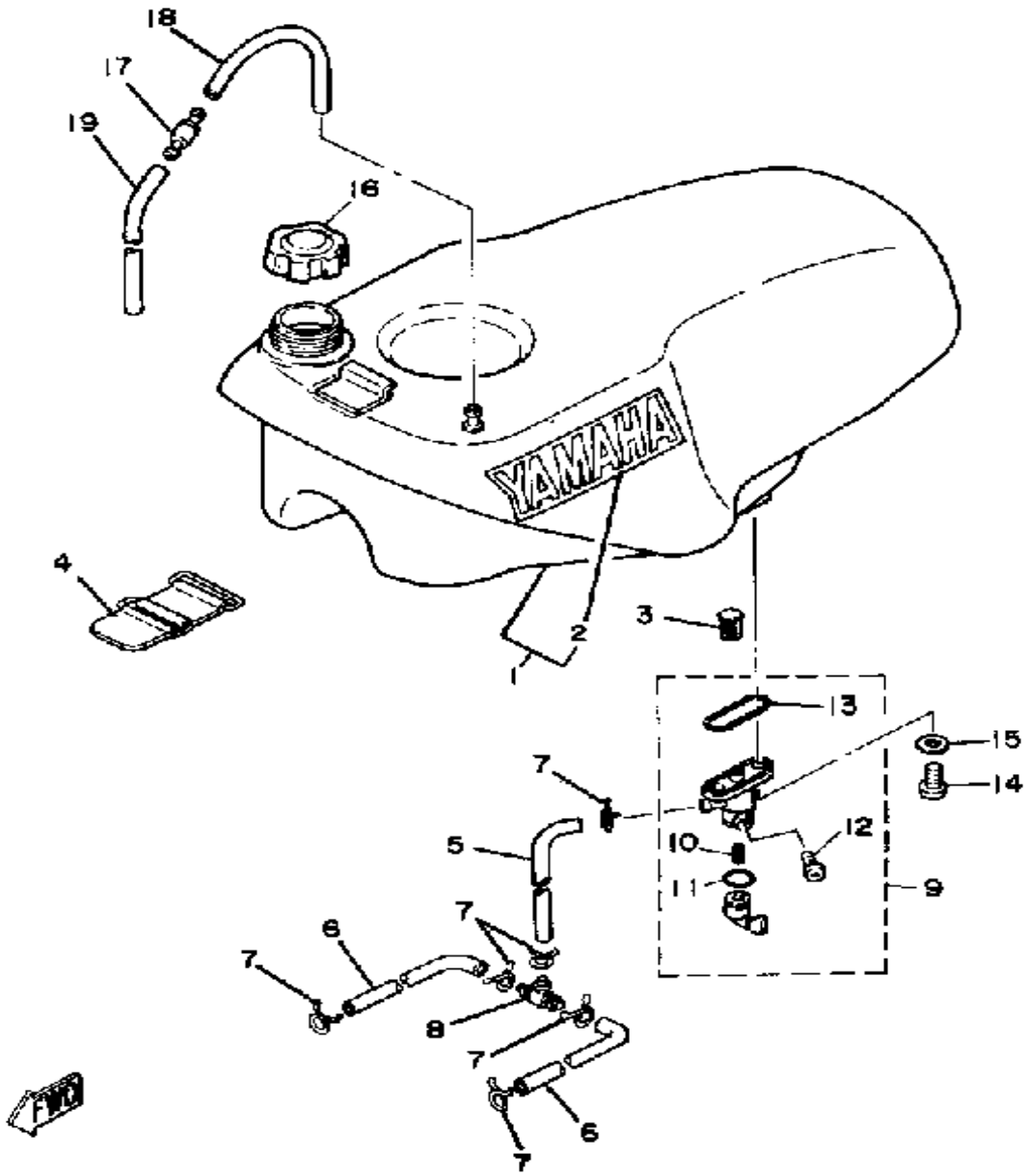

Ref. No.	Part Number	Description	Qty	Remarks
1	(5F7-24110-00-01)	FUEL TANK	1	
2	3G3-24161-00-00	. EMBLEM 1	2	
3	322-24514-00-00	NET, FILTER 1	1	
4	240-24173-00-00	BAND, TNK FITTING 1	1	
5	90445-11147-00	HOSE	1	
6	90445-11587-00	HOSE	2	
7	90467-10008-00	CLIP	6	
8	1X2-24376-00-00	JOINT, FUEL PIPE	1	
9	(5F7-24500-00-00)	FUEL COCK ASSEMBLY 1 ...	1	
10	1A0-24529-01-00	. SPRING	1	
11	1A0-24512-00-00	. GASKET	1	
12	619-24535-00-00	. SCREW, LVR FITTING	1	
13	214-24512-00-00	. GASKET	1	
14	90149-06008-00	SCREW	2	
15	90202-05187-00	WASHER, PLATE	2	
16	5F7-24610-00-00	CAP ASSEMBLY	1	
17	4A0-24380-00-00	PIPE JOINT ASSEMBLY	1	
18	90446-09130-00	HOSE	1	
19	90446-09183-00	HOSE	1	

SEAT

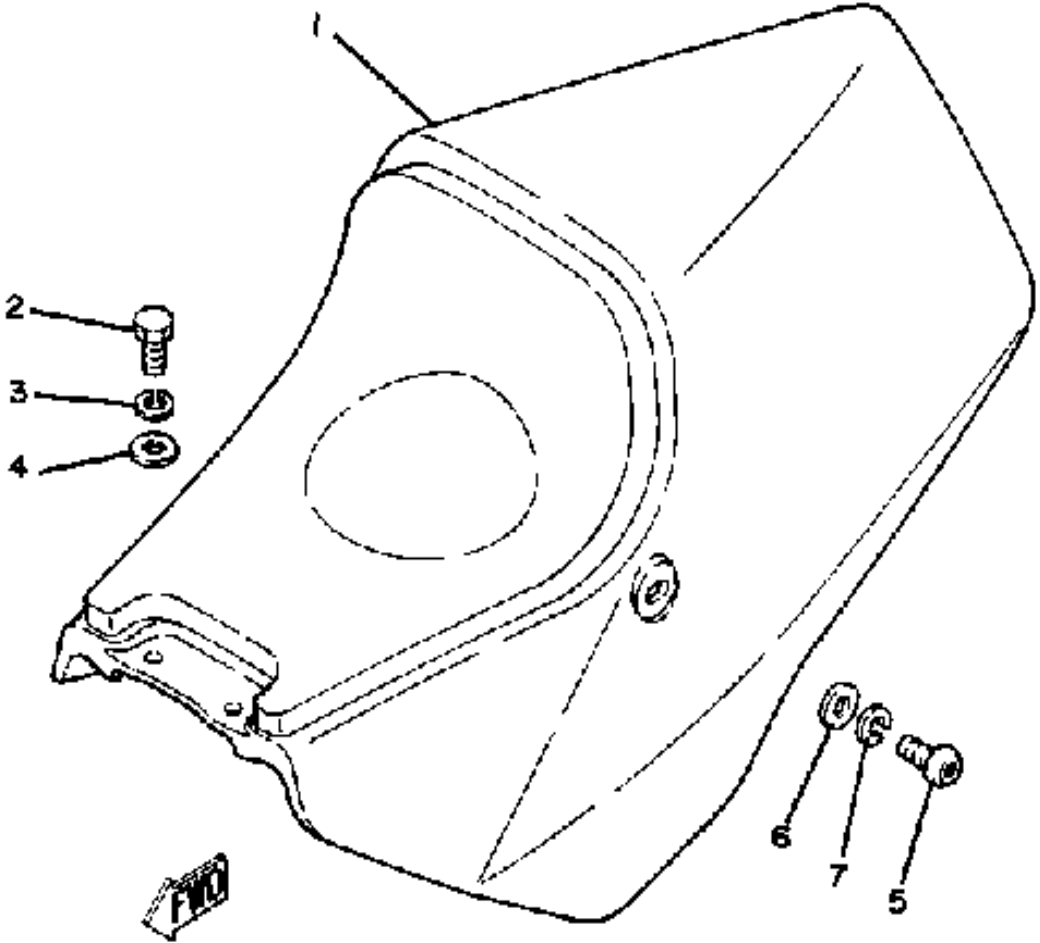

Ref. No.	Part Number	Description	Qty	Remarks
1	(26J-24710-00-E1)	SINGLE SEAT ASSEMBLY	1	
2	97016-06016-00	BOLT	2	
3	92906-06100-00	WASHER, SPRING	2	
4	90201-06057-00	WASHER, PLATE	2	
5	92016-08020-00	SCREW	2	
6	90201-086A3-00	WASHER, PLATE	2	
7	92906-08100-00	WASHER, SPRING	2	

FRONT WHEEL

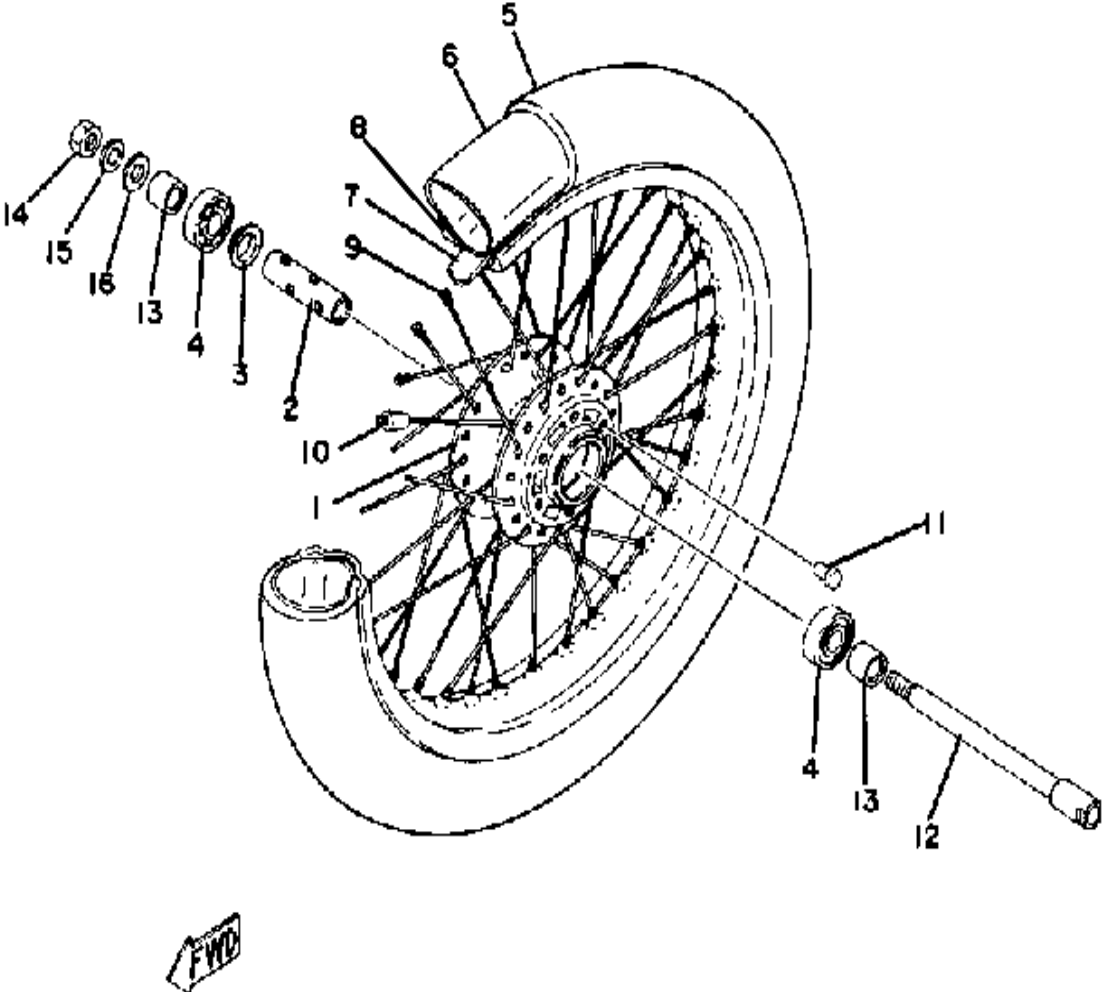

Ref. No.	Part Number	Description	Qty	Remarks
1	(1H3-25111-01-98)	HUB, FRONT	1	LOW GLOSS BLK
2	(409-25117-00-00)	SPACER, BEARING	1	
3	146-25315-00-00	FLANGE, SPACER	1	
4	93306-30309-00	BEARING	2	
8	(94418-18290-00)	RIM 1.85X 8	1	
9	(409-25104-00-00)	SPOKE SET, FRONT	1	
10	156-25398-00-00	BALANCER, WHEEL	1	U.N.
11	90338-07011-00	PLUG, SPEC'L SHAPE	6	
12	(409-25181-00-00)	AXLE, WHEEL	1	
13	(90387-17245-00)	COLLAR	2	
14	95312-14600-00	NUT	1	
15	92901-14100-00	WASHER, SPRING	1	
16	92990-14200-00	WASHER, PLAIN	1	

FRONT BRAKE CALIPER

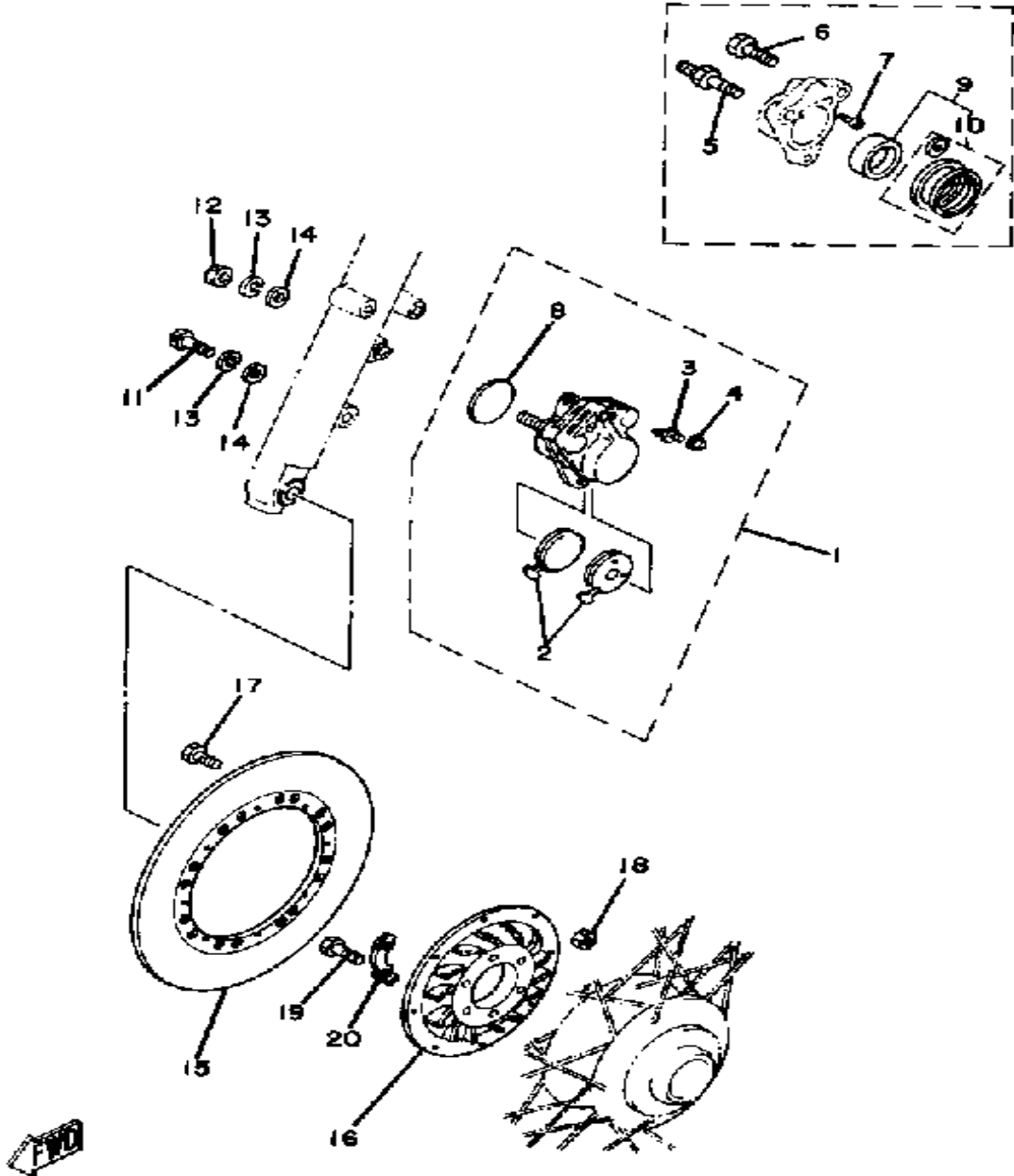

Ref. No.	Part Number	Description	Qty	Remarks
1	(409-25810-03-00)	CALIPER ASSEMBLY RH	1	
2	409-W0045-00-00	. BRAKE PAD KIT, FRNT	1	
3	306-25824-00-00	. SCREW, BLEED	1	
4	306-25825-01-00	. CAP	1	
5	306-25821-01-00	. BOLT 1	1	
6	306-25822-01-00	. BOLT 2	1	
7	306-25826-01-00	. BOLT 3	2	
8	306-25829-00-00	. EMBLEM, CALIPER	1	
9	(306-W0057-00-00)	PISTON ASSEMBLY, CALIPER	1	
10	856-W0047-00-00	. . CALIPER SEAL KIT (856-20000-50)	1	
11	(90103-10019-00)	BOLT, HEAD W/HOLE	1	
12	(90179-10119-00)	NUT, SPEC'L SHAPE	1	
13	92990-10100-00	WASHER, SPRING	2	
14	(90201-10130-00)	WASHER, PLATE	2	
15	(409-25831-00-00)	DISC, BRAKE	1	
16	(409-25832-00-00)	BRACKET, DISC	1	
17	90109-06018-00	BOLT	8	
18	95601-06100-00	NUT, U	8	
19	(90101-08272-00)	BOLT	6	
20	341-25412-00-00	WASHER	3	

REAR WHEEL

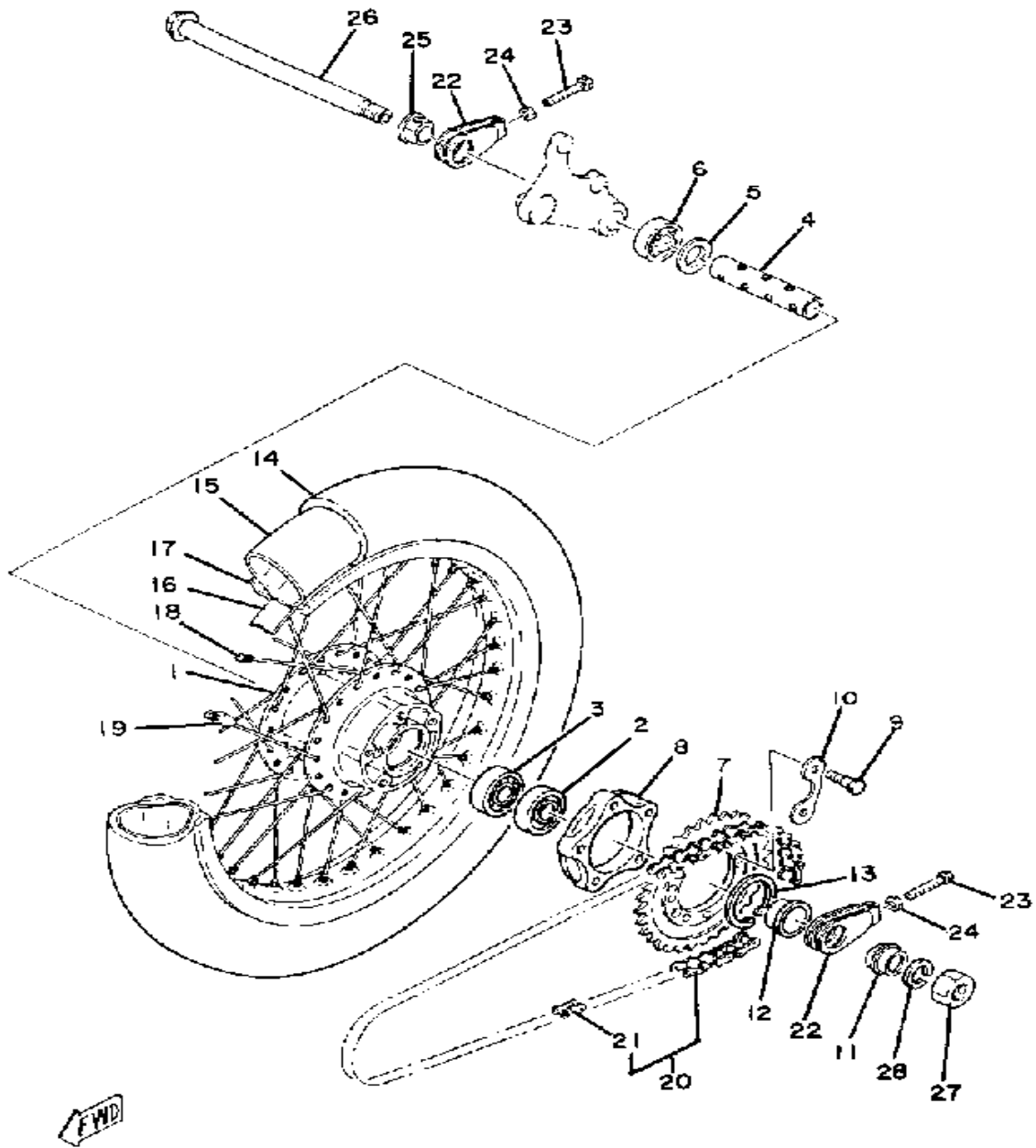

Ref. No.	Part Number	Description	Qty	Remarks
1	(1H3-25311-02-98)	HUB, REAR	1	LOW GLOSS BLK
2	93306-30417-00	BEARING (B6304ZZ)	1	
3	93306-30421-00	BEARING (B6304C3)	1	
4	(1H3-25317-00-00)	SPACER, BEARING	1	
5	4V4-25315-00-00	FLANGE, SPACER	1	
6	93306-20404-00	BEARING	1	
7	(240-25442-00-00)	SPROCKET, DRIVN 42T	1	ALT. PTS.
	240-25432-00-00	SPROCKET, DRIVN 32T	1	ALT. PTS.
	240-25433-00-00	SPROCKET, DRIVN 33T	1	ALT. PTS.
	240-25434-00-00	SPROCKET, DRIVN 34T	1	ALT. PTS.
	240-25435-00-00	SPROCKET, DRIVN 35T	1	U.R.STD
	240-25438-00-00	SPROCKET, DRIVN 38T	1	ALT. PTS.
	3YL-25436-00-00	SPROCKET, DRIVEN 6	1	ALT. PTS.
	3YL-25437-00-00	SPROCKET, DRIVEN 7	1	ALT. PTS.
	3YL-25439-00-00	SPROCKET, DRIVEN 9	1	ALT. PTS.
	3YL-25440-00-00	SPROCKET, DRIVEN 0	1	ALT. PTS.
	3YL-25441-00-00	SPROCKET, DRIVEN 1	1	ALT. PTS.
8	5F7-25316-00-00	FLANGE, SPACER 2	1	
9	90109-08618-00	BOLT	5	
10	143-25412-00-00	WASHER	3	
19	156-25398-00-00	BALANCER, WHEEL	1	U.N.
20	9Y58E-20097-00	DID520DS-98L (DID520DS 98L)	1	
21	(94645-20031-00)	JOINT CHAIN	1	
22	3G2-25388-00-00	PULLER, CHAIN 1	2	
23	90101-08699-00	BOLT	2	
24	95303-08700-00	NUT	2	
25	(3G2-25384-00-00)	WASHER, WHEEL	2	
26	(5F7-25381-00-00)	AXLE, WHEEL	1	
27	90170-18091-00	NUT, HEXAGON	1	

CONTINUED ON NEXT FRAME ➤

REAR WHEEL

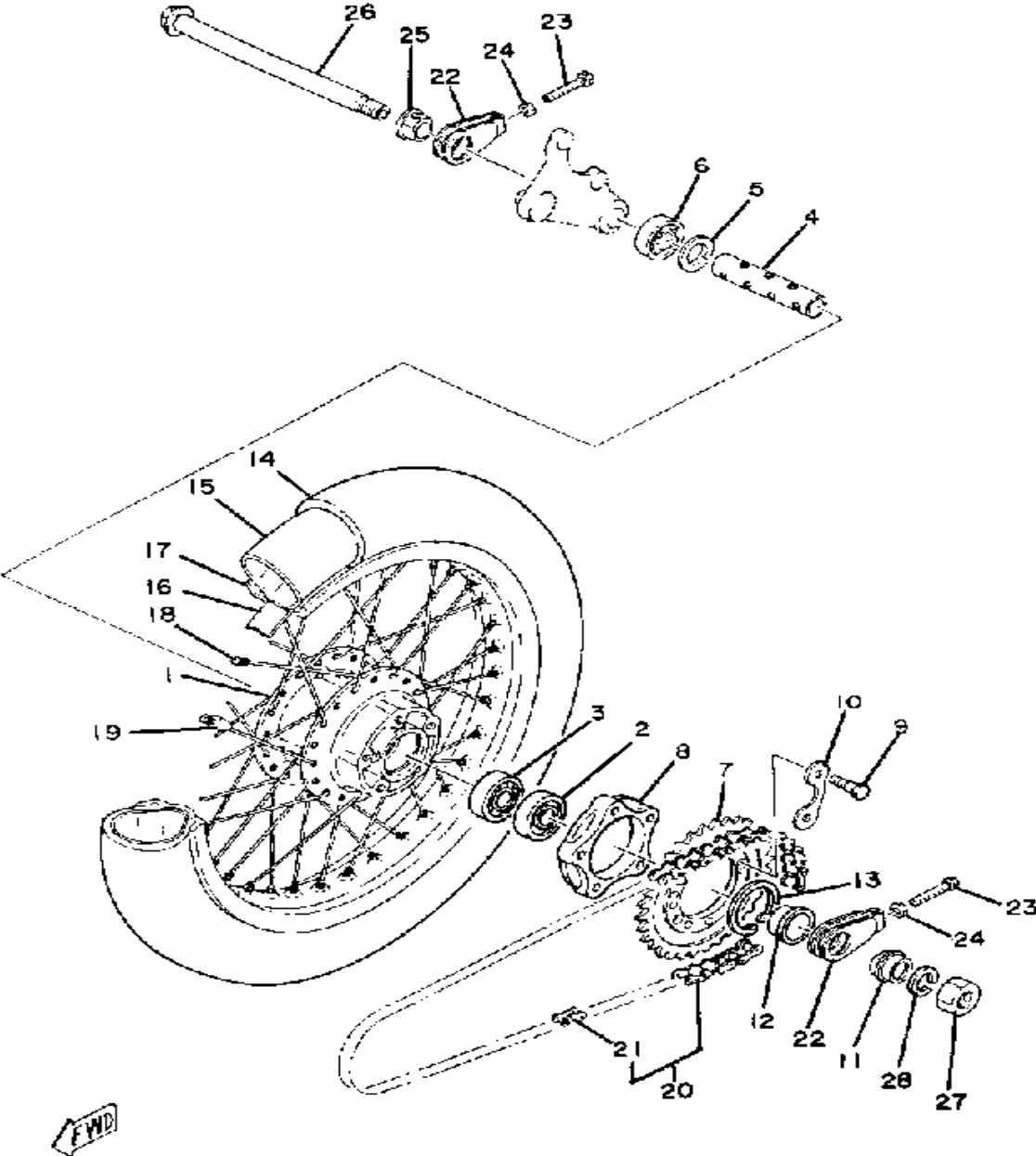

Ref. No.	Part Number	Description	Qty	Remarks
28	92901-18100-00	WASHER, SPRING	1	

REAR BRAKE CALIPER

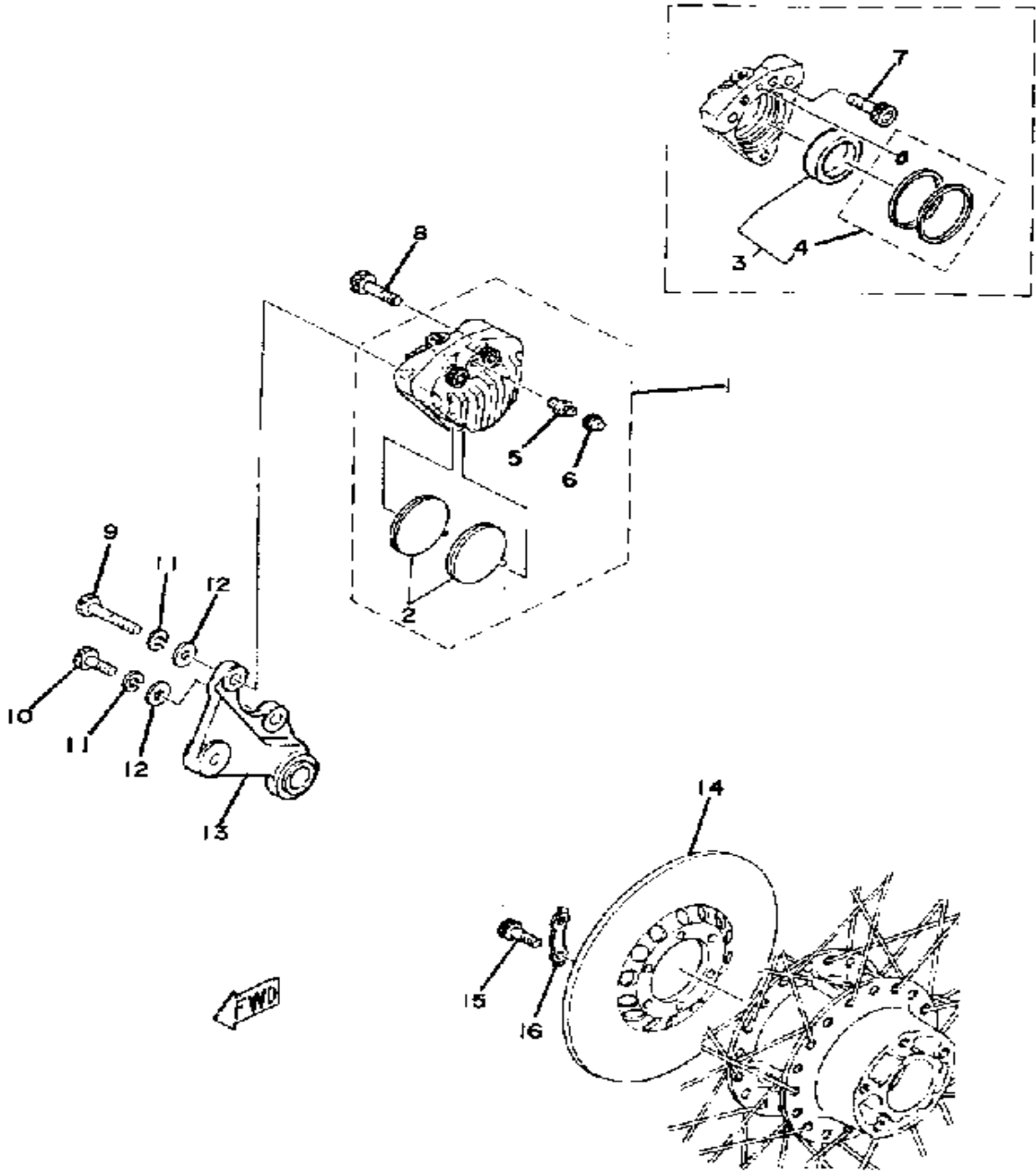

Ref. No.	Part Number	Description	Qty	Remarks
1	(5F7-25810-50-00)	CALIPER ASSEMBLY	1	
2	(4A0-W0046-00-00)	BRAKE PAD KIT, REAR	1	
3	(1X2-W0057-00-00)	PISTON ASSEMBLY, CALIPER	1	
4	1X2-W0047-00-00	.. CALIPER SEAL KIT	1	
5	306-25824-00-00	. SCREW, BLEED	1	
6	306-25825-01-00	. CAP	1	
7	91316-10030-00	. BOLT, SOCKET HEAD	1	
8	91311-10040-00	BOLT	1	
9	(90103-10022-00)	BOLT, HEAD W/HOLE	1	
10	(90103-10021-00)	BOLT, HEAD W/HOLE	1	
11	92990-10100-00	WASHER, SPRING	2	
12	92990-10600-00	WASHER, PLATE	2	
13	(3G2-25819-00-00)	BRACKET, CALIPER	1	
14	(1H3-25831-00-00)	DISC, BRAKE	1	
15	90109-08432-00	BOLT	6	
16	341-25412-00-00	WASHER	3	

HANDLEBAR - CABLE

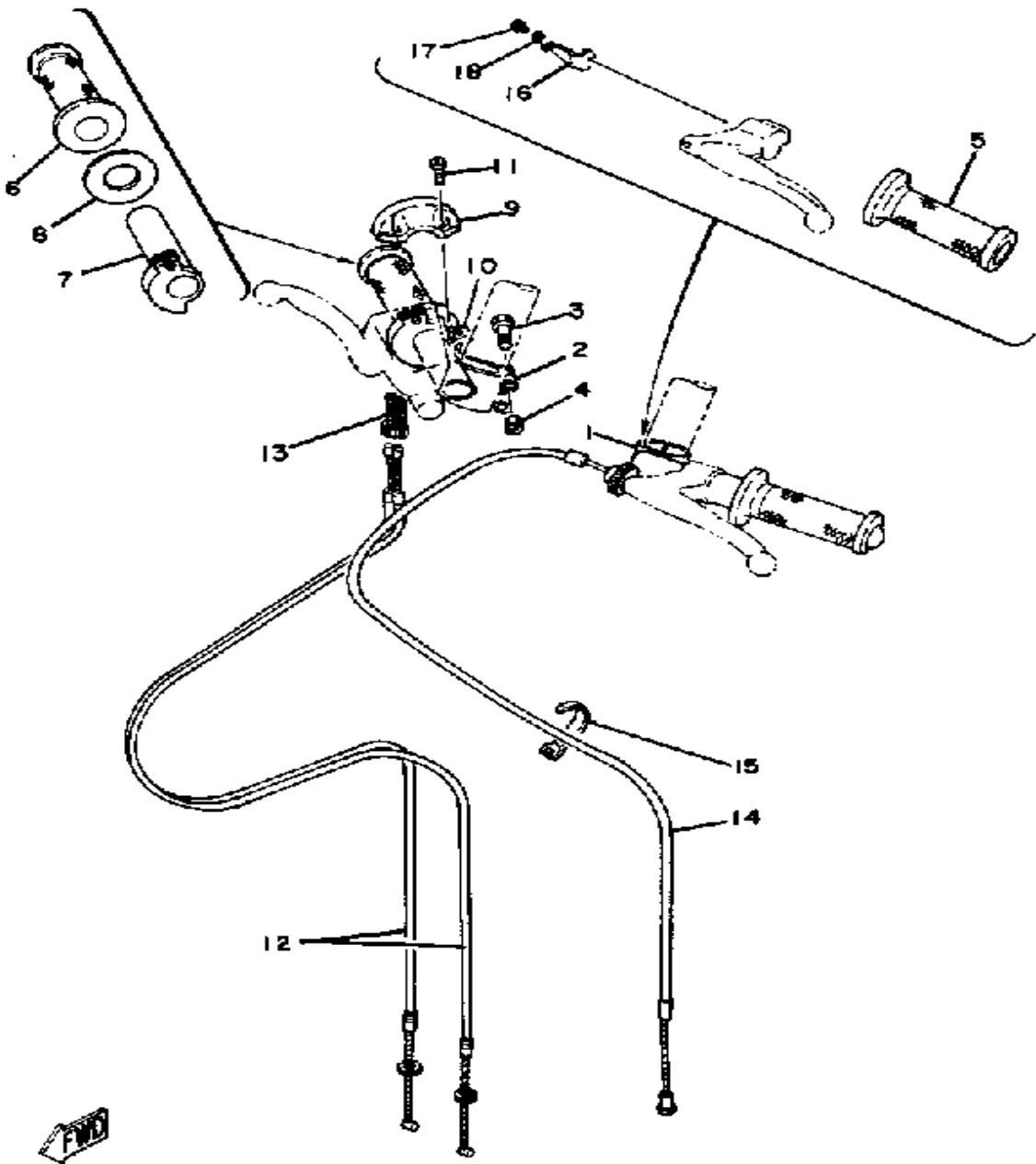

Ref. No.	Part Number	Description	Qty	Remarks
1	5F7-26121-01-00	HANDLEBAR LH	1	
2	5F7-26122-01-00	HANDLEBAR RH	1	
3	97313-08035-00	BOLT, HEXAGON	4	
4	95611-08100-00	NUT, U	4	
5	47X-26241-00-00	GRIP (LEFT)	1	
6	47X-26242-00-00	GRIP (RIGHT)	1	
7	5F7-26243-00-00	TUBE, THRTL GUIDE	1	
8	3Y1-26249-00-00	RING, LEAF	1	
9	3G2-26281-01-00	CAP, GRIP UPPER	1	
10	3G2-26282-01-00	CAP, GRIP LOWER	1	
11	98580-05020-00	SCREW, PAN HEAD	2	
12	5F7-26311-01-00	CABLE, THROTTLE 1	2	
13	90123-06007-00	BOLT	2	
14	5F7-26335-00-00	CABLE, CLUTCH	1	
15	90464-14117-00	CLAMP	1	
16	5F6-26368-00-00	SPRING, LOCK	1	
17	98580-05010-00	SCREW, PAN HEAD	1	
18	92990-05100-00	WASHER, SPRING	1	

FRONT MASTER CYLINDER

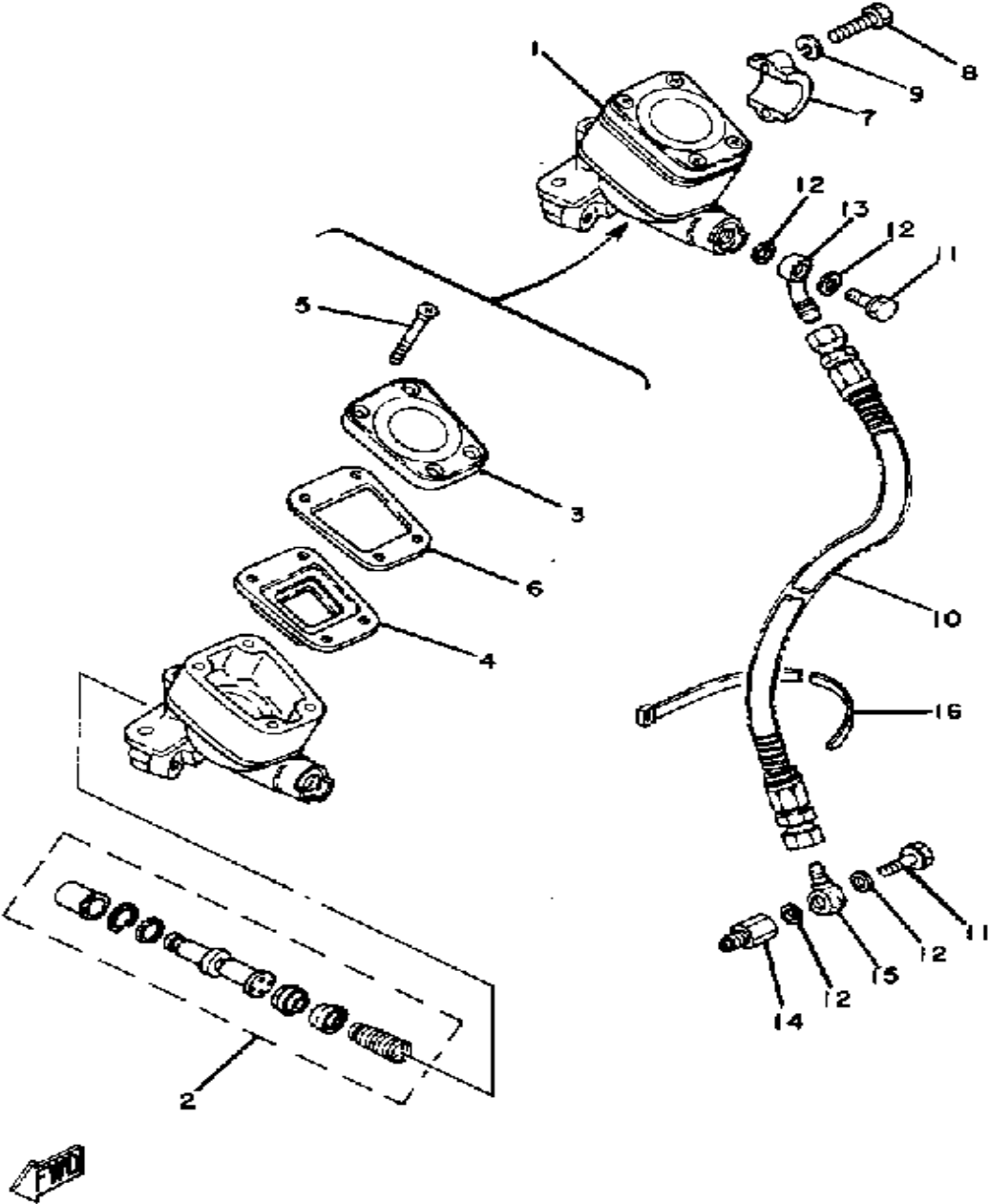

Ref. No.	Part Number	Description	Qty	Remarks
1	(5F7-25850-00-00)	MSTR CYLINDER ASSEMBLY	1	
2	535-W0041-60-00	. CYLINDER KIT, MASTER	1	
3	1J3-25852-01-00	. CAP, RESERVOIR	1	
4	1J3-25854-01-00	. DIAPHRAGM RESERVOR	1	
5	98706-05030-00	. SCREW, FLAT HEAD	4	
6	1J3-25855-01-00	. BUSH, DIAPHRAGM	1	
7	1J3-25867-00-00	BRACKET, MASTER CYLINDER (341-25867-00)	1	
8	97011-06025-00	BOLT (97001-06025)	2	
9	92995-06100-00	WASHER, SPRING	2	
10	(5F7-25873-00-00)	HOSE, BRAKE 2	1	
11	(90401-10062-00)	BOLT, UNION	2	
12	90201-10118-00	WASHER, PLATE	4	
13	(5F7-25885-00-00)	JOINT	1	
14	(4A0-25885-00-00)	JOINT	1	
15	(1X2-25885-20-00)	JOINT	1	
16	90464-14117-00	CLAMP	1	

REAR MASTER CYLINDER

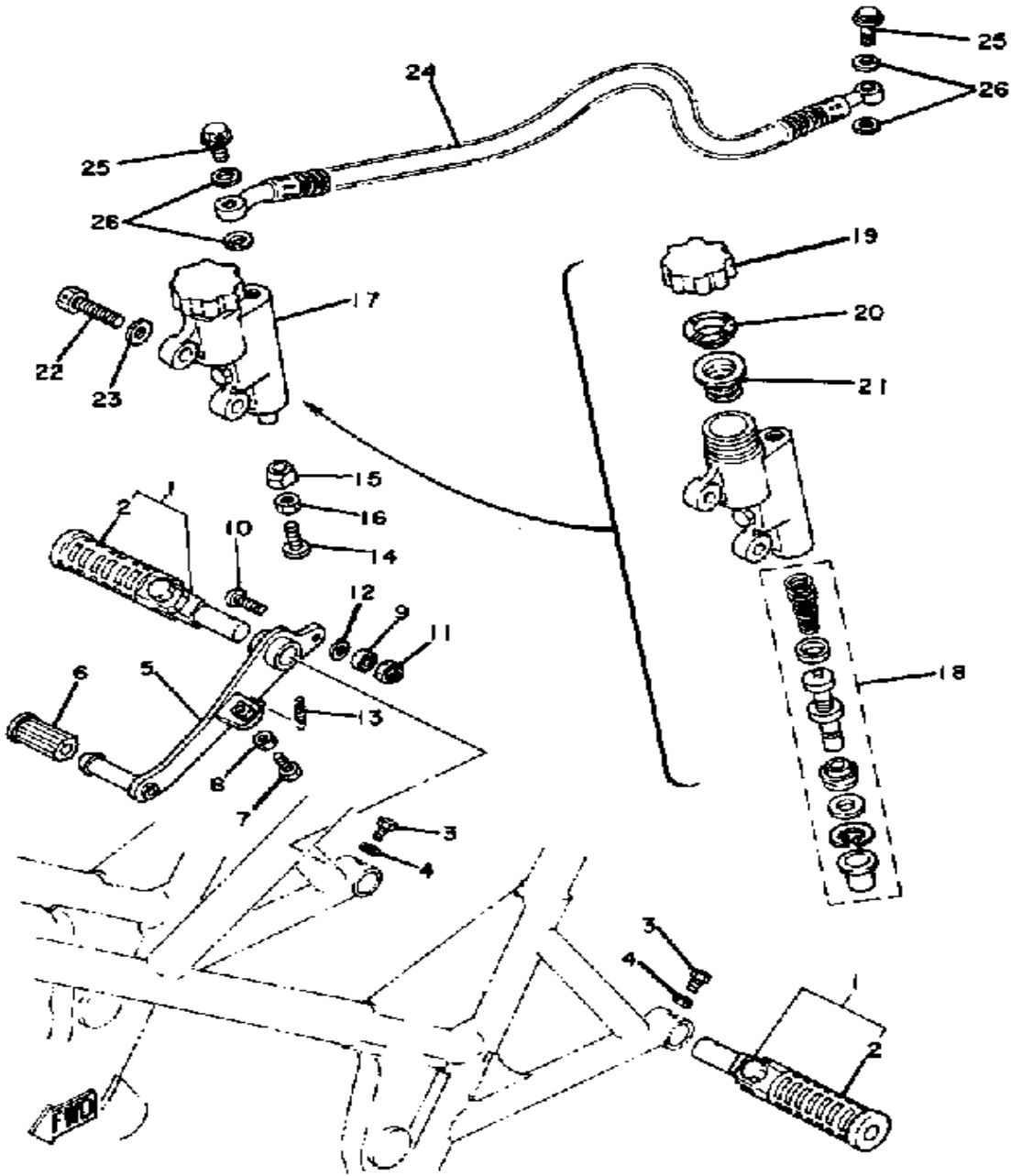

Ref. No.	Part Number	Description	Qty	Remarks
1	(5F7-27410-00-00)	FRT FOOTREST ASSEMBLY L	2	
	5F7-27410-10-00	FRT FOOTREST ASSEMBLY L	2	
2	1X2-27413-00-00	. COVER, FOOTREST	1	
3	97016-06016-00	BOLT	2	
4	92906-06100-00	WASHER, SPRING	2	
5	(5F7-27211-00-00)	PEDAL, BRAKE	1	
6	240-18113-00-00	COVER, SHIFT PEDAL	1	
7	90101-06288-00	BOLT	1	
8	95380-06700-00	NUT	1	
9	93300-69606-00	BEARING	1	
10	92016-06020-00	SCREW	1	
11	90185-06040-00	NUT, SELF-LOCKING	1	
12	90185-06040-00	NUT, SELF-LOCKING	2	
13	(5F7-27216-00-00)	SPRING, BRAKE PEDAL	1	
14	4A0-27227-00-00	BOLT, ADJUSTING	1	
15	4A0-27238-00-00	NUT, ADJUSTING	1	
16	95380-06700-00	NUT	1	
17	(5F7-25850-50-00)	MSTR CYLINDER ASSEMBLY	1	
18	(4A0-W0042-50-00)	CYLINDER KIT, MASTER	1	
19	(1X2-25852-50-00)	CAP, RESERVOIR	1	
20	(1X2-25855-50-00)	BUSH, DIAPHRAGM	1	
21	(1X2-25854-50-00)	DIAPHRAGM RESERVOR	1	
22	(90103-08015-00)	BOLT, HEAD W/HOLE	2	
23	92901-08600-00	WASHER	2	
24	(5F7-25872-00-00)	HOSE, BRAKE 1	1	
25	(90401-10062-00)	BOLT, UNION	2	
26	90201-10118-00	WASHER, PLATE	4	

COWLING

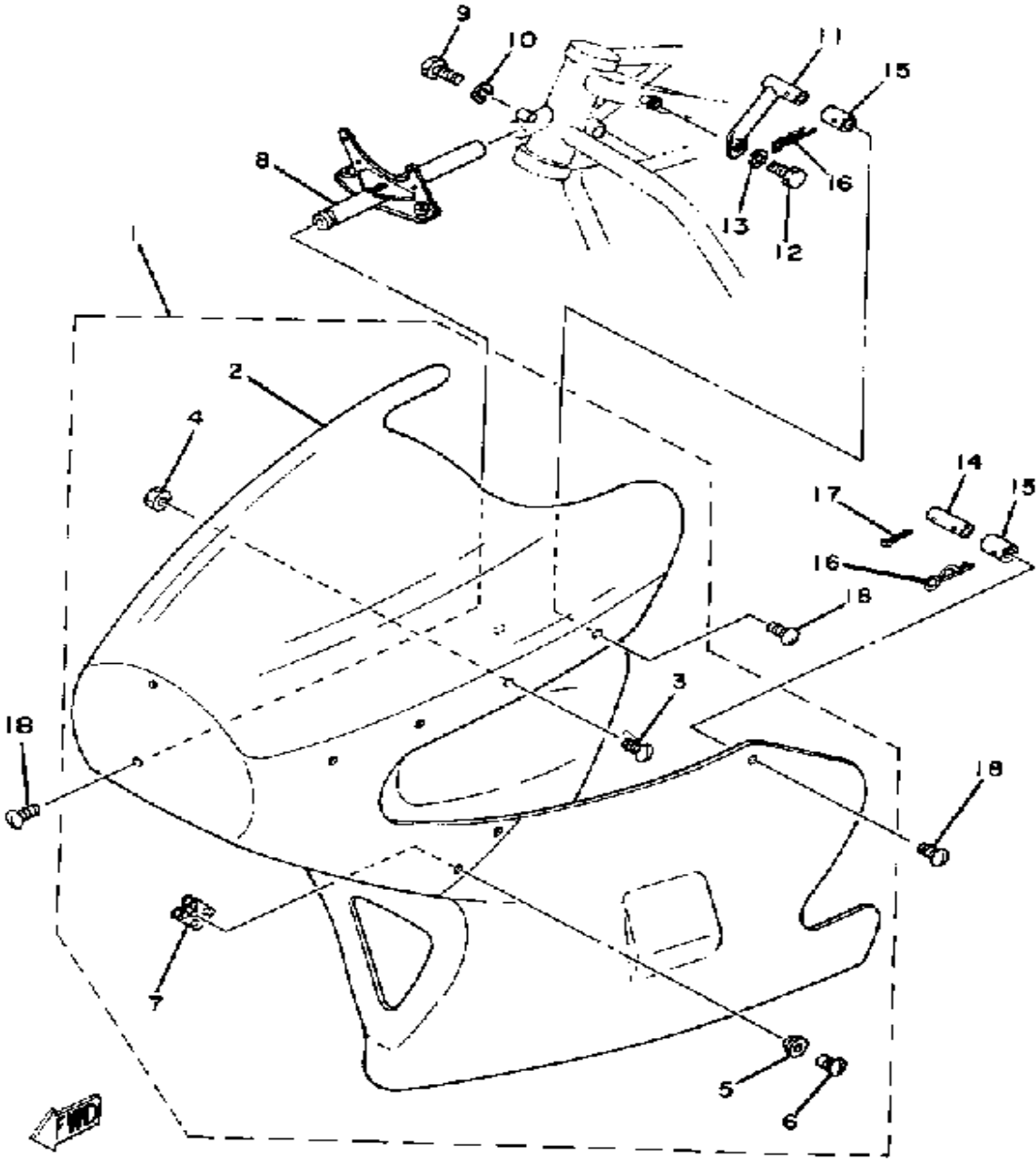

Ref. No.	Part Number	Description	Qty	Remarks
3	90140-04012-00	. SCREW, ROUND HEAD	7	
4	95301-04600-00	. NUT	7	
5	240-28386-00-00	. HEAD	4	
6	240-28389-00-00	. RIVET	4	
7	4A0-W2831-00-00	. RNFCMNT, COWLING	4	
8	(5F7-28356-00-00)	STAY 1	1	
9	97313-08020-00	BOLT, HEXAGON	1	
10	92990-08100-00	WASHER	1	
11	5F7-28357-00-00	STAY 2	2	
12	97026-06012-00	BOLT	2	
13	92906-06100-00	WASHER, SPRING	2	
14	5F7-28358-00-00	STAY 3	2	
15	4A0-28364-00-00	NUT	4	
16	90468-20100-00	CLIP	4	
17	91401-25020-00	PIN, COTTER	2	
18	90140-06010-00	SCREW, ROUND HEAD (143-28353-00)	5	

METER

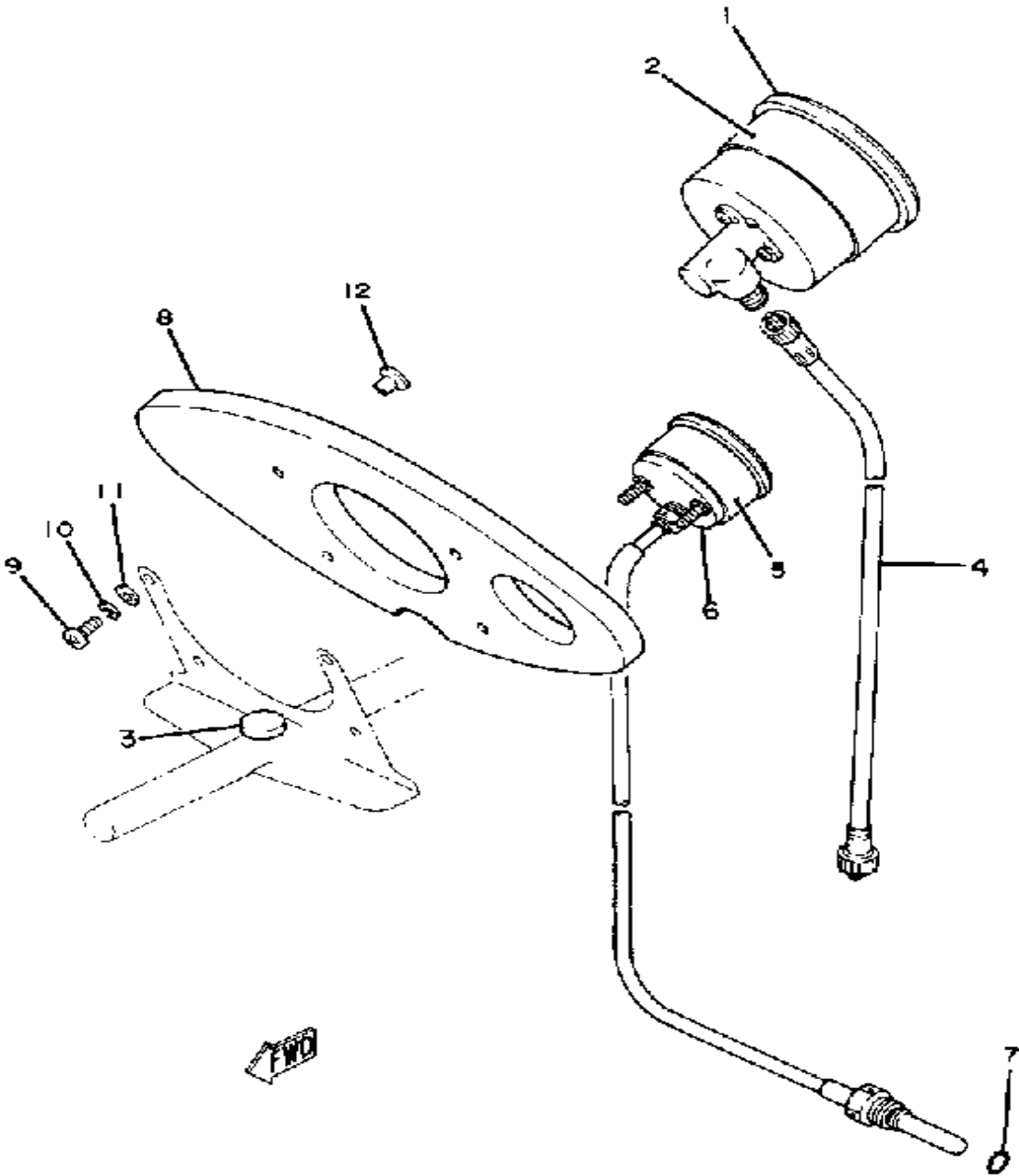

Ref. No.	Part Number	Description	Qty	Remarks
1	5A0-83540-00-00	TACHOMETER ASSEMBLY ...	1	
2	3TC-24723-00-00	DAMPER, SEAT	1	
3	4A0-85547-00-00	DAMPER	1	
4	5F7-83560-00-00	TACHOMETER CABLE	1	
5	3YF-24724-00-00	DAMPER, SEAT (4A0-83592-00)	1	
6	4A0-83590-01-00	WATER TEMP. ASSEMBLY ...	1	
7	93210-10118-00	O-RING	1	
8	4A0-83611-00-00	PANEL, METER	1	
9	98580-04010-00	SCREW, PAN HEAD	4	
10	92901-04100-00	WASHER, SPRING	4	
11	92901-04600-00	WASHER, PLATE	4	
12	4A0-83522-00-00	COLLAR	4	

ELECTRICAL 1

Ref. No.	Part Number	Description	Qty	Remarks
1	2X6-82310-10-00	IGNITION COIL ASSEMBLY ...	2	
2	98511-06025-00	SCREW PAN HEAD (92501-06025)	4	
3	92995-06100-00	WASHER, SPRING	4	
4	81E-82370-20-00	PLUG CAP ASSEMBLY	2	U.R.
	8E7-82370-11-00	PLUG CAP ASSEMBLY	2	U.R.W/NOISE SUPPRESSOR

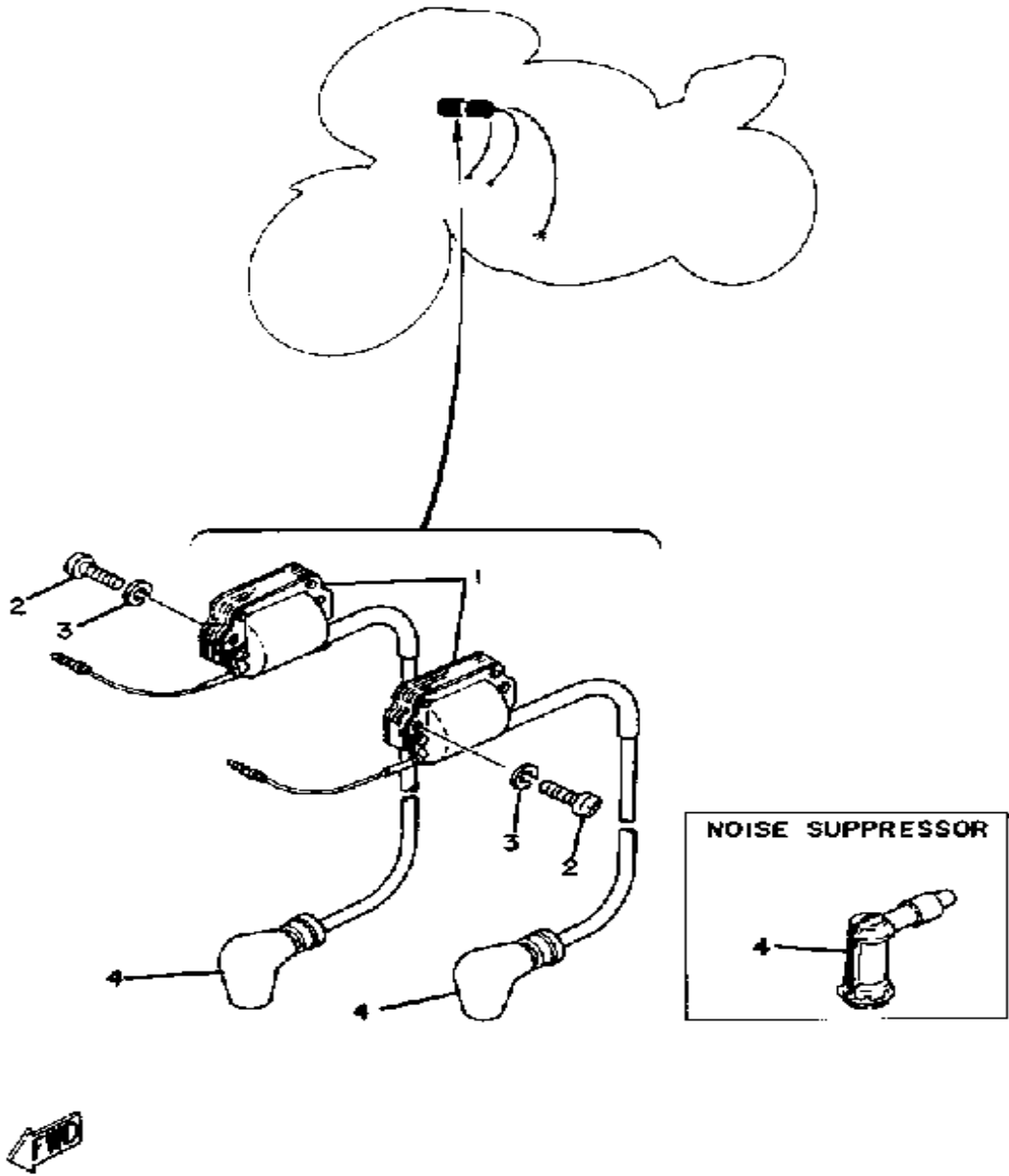

HANDLE SWITCH - LEVER

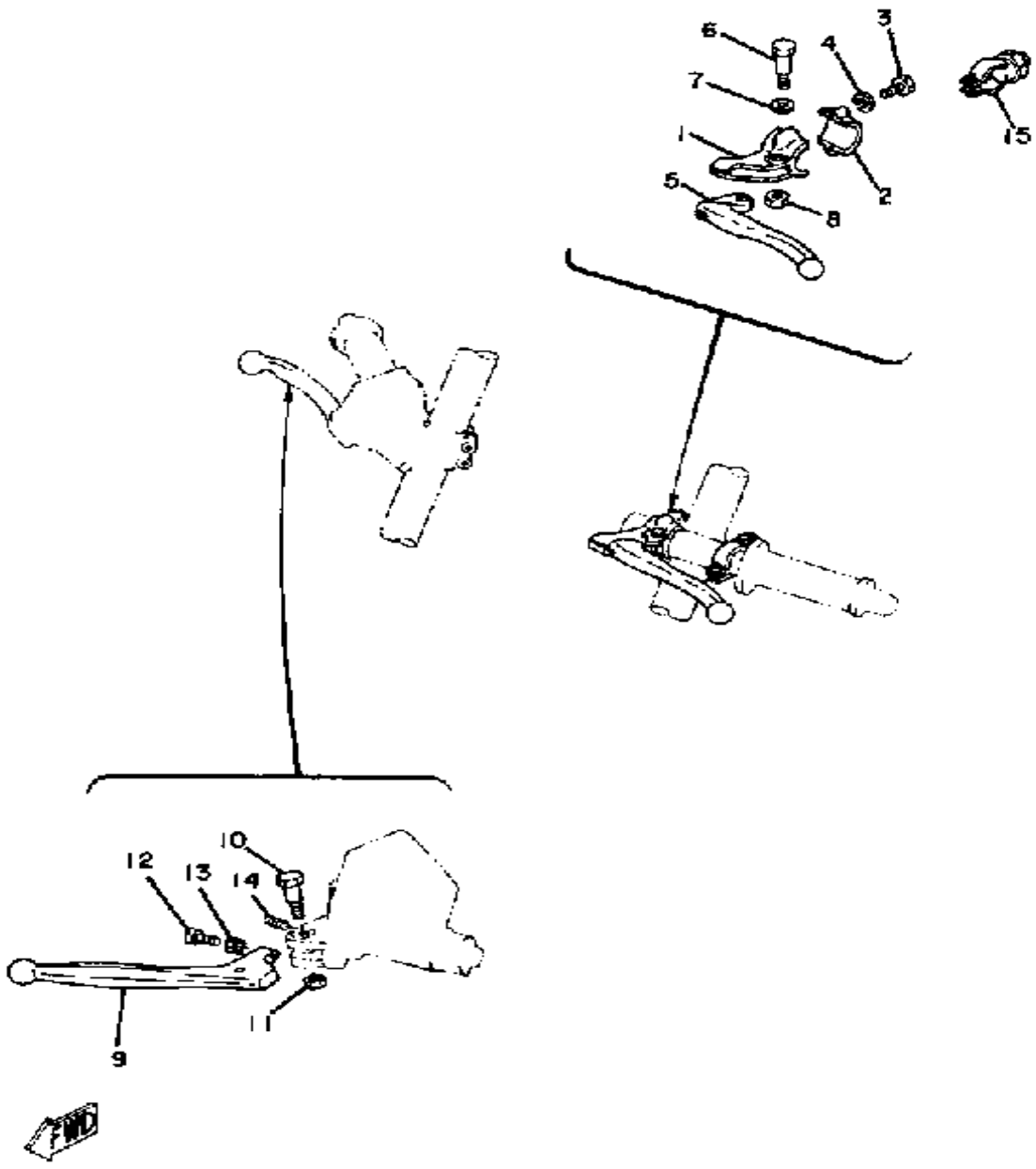

Ref. No.	Part Number	Description	Qty	Remarks
1	5F6-82911-00-00	HOLDER, LEVER 1	1	
2	4V4-82913-00-00	HOLDER, LEVER LOWER 1	1	
3	97006-05020-00	BOLT (97206-05020)	2	
4	92906-05100-00	WASHER, SPRING	2	
5	214-83912-00-00	LEVER 1	1	
6	90109-06797-00	BOLT	1	
7	90201-08083-00	WASHER, PLATE	1	
8	95601-06100-00	NUT, U	1	
9	1V1-83922-00-00	LEVER R	1	
10	90109-06465-00	BOLT	1	
11	95380-06700-00	NUT	1	
12	90149-06131-00	SCREW	1	
13	90170-06010-00	NUT	1	
14	90501-10312-00	SPRING, COMPRESSION	1	
15	3LC-83976-00-00	SWITCH, HANDLE 1	1	