



**YAMAHA**

**GENUINE**

**PARTS CATALOGUE**

**MOTORCYCLE**

# CYLINDER HEAD - CYLINDER

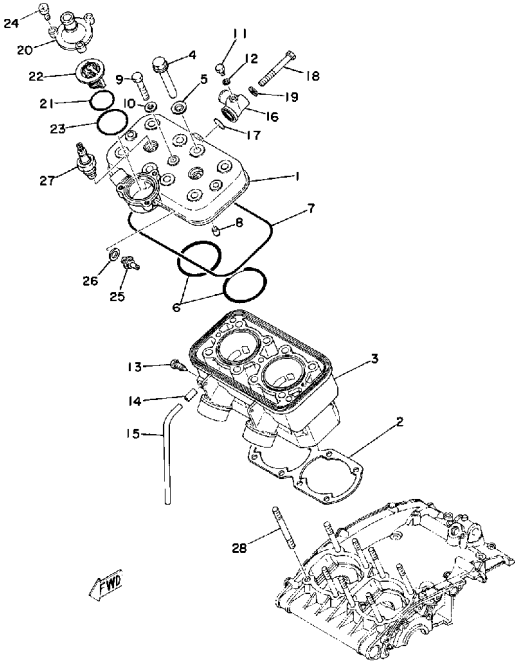

Ref. No.	Part Number	Description	Qty	Remarks
1	(1H3-11111-01-00)	HEAD, CYLINDER 1	1	
2	383-11351-01-00	GASKET, CYLINDER	1	
3	1H3-11311-02-00	CYLINDER 1	1	
4	90179-08187-00	NUT, SPEC'L SHAPE	8	
5	90201-12172-00	WASHER, PLATE	8	
6	93210-69434-00	O-RING	2	
7	93211-94212-00	O-RING	1	
8	99590-10014-00	PIN, DOWEL	2	
9	95021-08055-00	BOLT, FLANGE	3	
10	90201-08087-00	WASHER, PLATE	3	
11	90338-06041-00	PLUG	1	
12	90430-06166-00	GASKET	1	
13	90340-10016-00	PLUG, STRAIGHT SCRW (383-11374-00)	1	
14	383-11375-00-00	NIPPLE, HOSE 1	1	
15	(3G2-11377-00-00)	HOSE	1	
16	(383-12498-00-00)	JOINT	1	
17	93210-20027-00	O-RING	1	
18	90105-08013-00	BOLT, WASHER BASED	1	
19	90210-08002-00	WASHER, SEAL	1	
20	383-12413-00-00	COVER, THERMOSTAT	1	
21	93210-40659-00	O-RING	1	
22	717-12411-00-00	THERMOSTAT	1	
23	93210-45150-00	O-RING	1	
24	98506-06016-00	SCREW, PANHEAD	3	
25	383-12499-00-00	JOINT	1	
26	90201-10128-00	WASHER, PLATE	1	
27	(CMP-N82G0-00-00)	CHAMPION N82G 10PK	2	
28	(90116-08213-00)	BOLT, STUD	8	M8-94L

# CRANKCASE

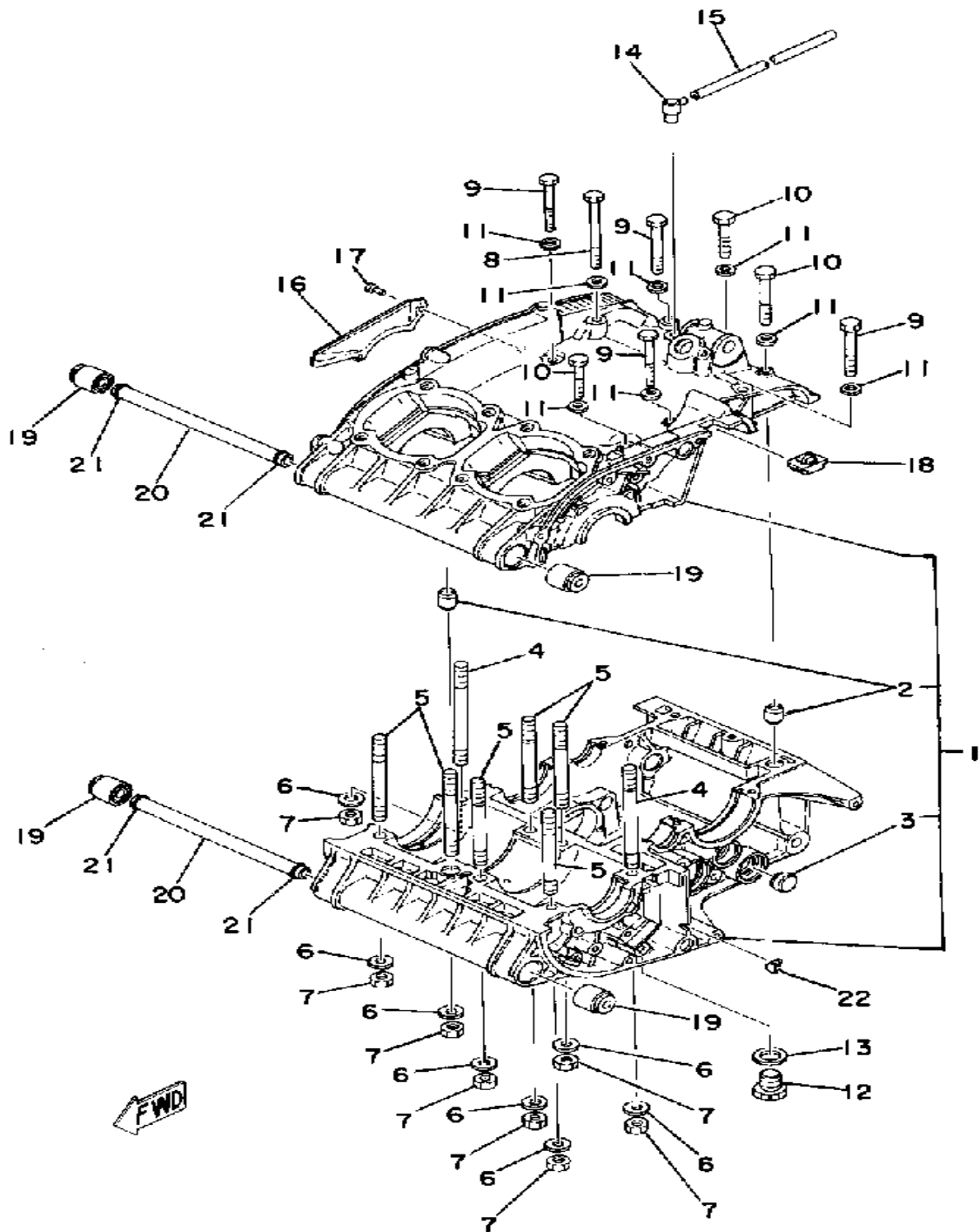

Ref. No.	Part Number	Description	Qty	Remarks
1	(1H3-15100-00-00)	CRANKCASE ASSEMBLY	1	
2	99510-12016-00	. PIN, DOWEL	2	
3	(90338-17016-00)	PLUG, SPEC'L SHAPE	1	
4	90116-08232-00	BOLT, STUD	2	M8-116L
5	90116-08064-00	BOLT, STUD	6	M8-97L
6	90201-08200-00	UNAVAILABLE IN PRICE BOOK	8	
7	95333-08600-00	NUT	8	
8	97311-06090-00	BOLT, HEXAGON	1	
9	97313-06055-00	BOLT, HEXAGON (97322-06055)	4	
10	97313-06045-00	BOLT (97021-06045-00)	3	
11	92990-06200-00	WASHER	8	
12	90340-14033-00	PLUG, STRAIGHT SCRW	1	
13	214-11198-01-00	GASKET	1	
14	583-15371-00-00	BREATHER	1	
15	90446-07112-00	HOSE	1	
16	278-15492-01-00	COVER	1	
17	98580-05010-00	SCREW, PAN HEAD	2	
18	278-15441-00-00	HOLDER, CLCH CABLE	1	
19	328-15316-00-00	DAMPER, ENG MOUNT 1 (328-15316-00)	4	
20	328-15317-00-00	SPACER, ENG MOUNT	2	
21	93210-12131-00	O-RING	4	
22	(129-15489-10-00)	GROMMET	1	

# CRANKCASE COVER

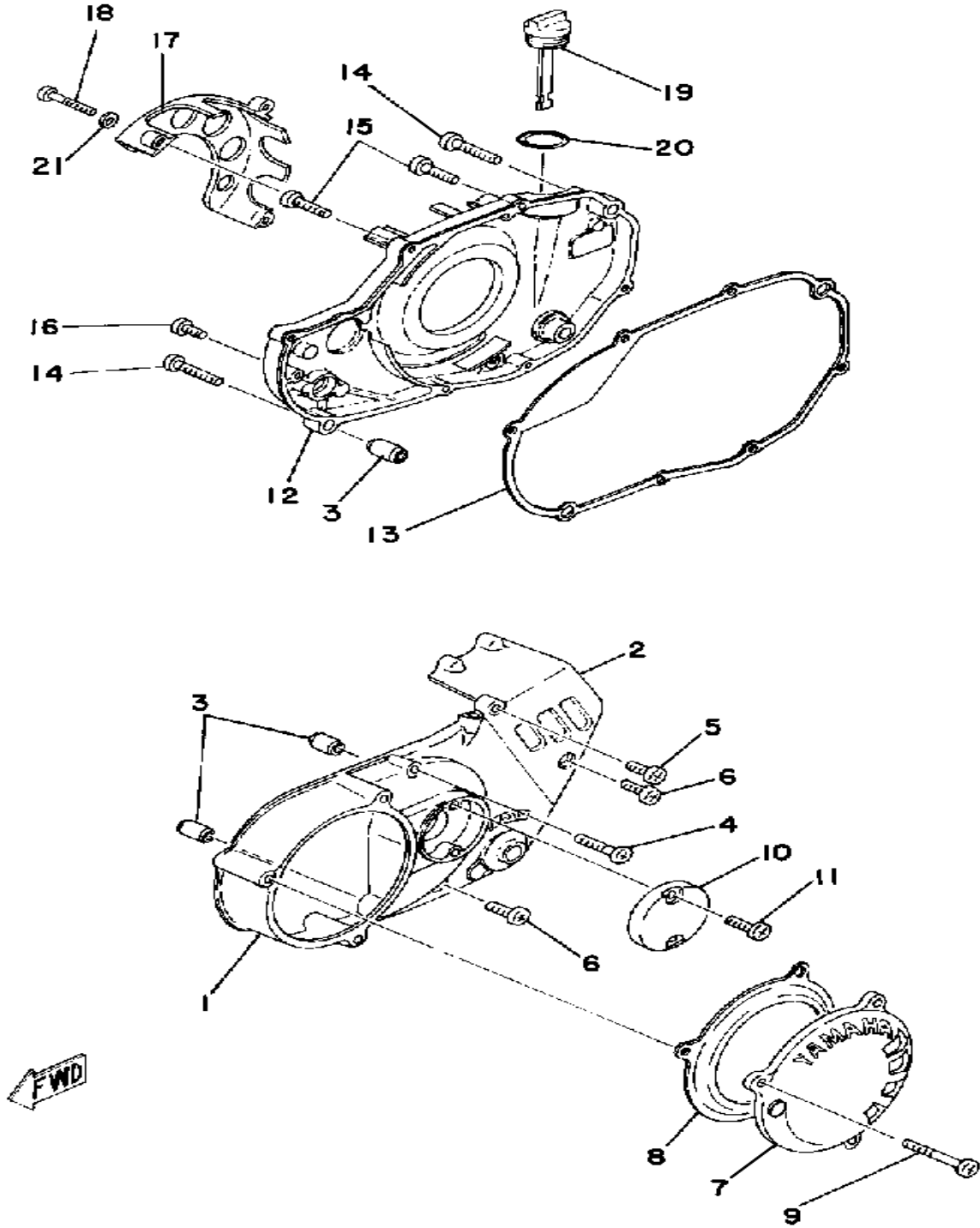

Ref. No.	Part Number	Description	Qty	Remarks
1	(1H3-15411-00-00)	COVER, CRANKCASE L	1	
2	(1H3-15421-00-00)	COVER, CRANKCASE R	1	
3	99510-12016-00	PIN, DOWEL	4	
4	98506-06035-00	SCREW, PAN HEAD	1	
5	98506-06025-00	SCREW, PAN HEAD	1	
6	98516-06020-00	SCREW, PAN HEAD	2	
7	(1H3-15415-00-00)	COVER, GENERATOR	1	
8	1H3-15455-00-00	GASKET 1	1	
9	98506-06060-00	SCREW, PAN HEAD	3	
10	1A0-15417-00-00	COVER, CAP	1	
11	(92506-05020-00)	SCREW, PAN HEAD	2	
12	(3G2-15421-00-00)	COVER, CRANKCASE R	1	
13	278-15461-02-00	GASKET, CRCS CVR 2	1	
14	98506-06040-00	SCREW, PAN HEAD	2	
15	98516-06030-00	SCREW, PAN HEAD	6	
16	98506-06025-00	SCREW, PAN HEAD	1	
17	(3G2-15416-00-00)	COVER, OIL PUMP	1	
18	98506-06040-00	SCREW, PAN HEAD	3	
19	(383-15363-00-00)	PLUG, OIL	1	
20	93210-27778-00	O-RING	1	
21	92901-06600-00	WASHER	3	

# CRANK - PISTON

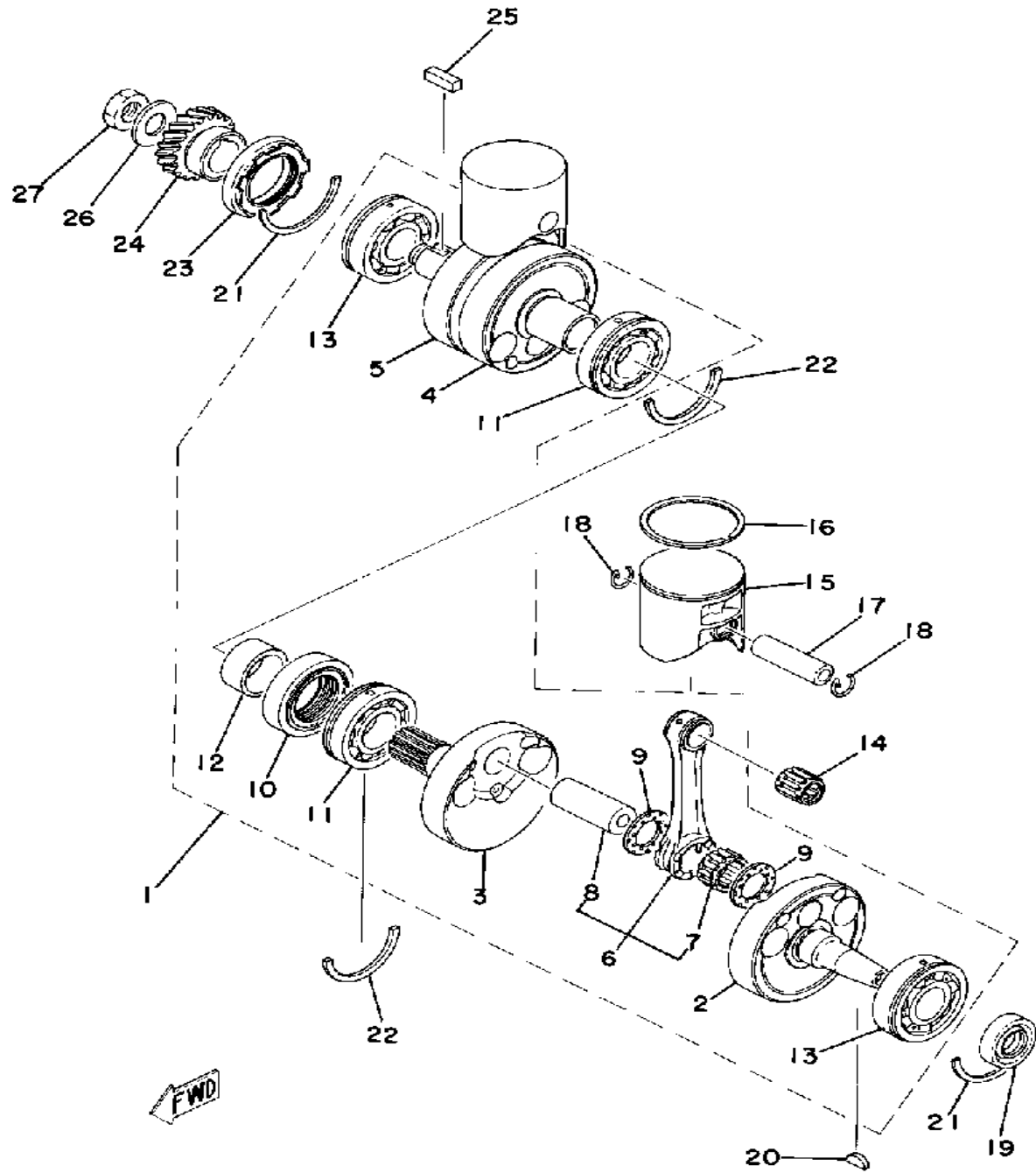

Ref. No.	Part Number	Description	Qty	Remarks
1	3G2-Y1140-00-00	CRANKSHAFT ASSEMBLY	1	
2	328-11412-02-00	. CRANK 1	1	
3	(328-11422-02-00)	CRANK 2	1	
4	(328-11432-02-00)	CRANK 3	1	
5	(328-11442-02-00)	CRANK 4	1	
6	3G2-11650-09-00	. CONNECTING ROD ASSEMBLY	2	
7	93310-422C8-00	.. BEARING, CYLINDER.	2	
8	8G8-11681-00-00	.. PIN, CRANK 1	2	
9	90209-22248-00	. WASHER	4	
10	328-11515-00-00	. SEAL, LABYRINTH 1	1	
11	93306-20614-00	. BEARING	2	
12	90387-32204-00	. COLLAR (328-11513-00)	1	
13	93390-00012-00	. BEARING, CYLINDER. # 0	2	
14	93310-216L2-00	BEARING, CYLINDRICAL	2	
15	430-11631-01-96	PISTON STD (53.97MM)	2	U.R.
16	329-11611-00-00	RING, PISTON STD	2	
17	280-11633-00-00	PIN, PISTON	2	
18	93450-17025-00	CIRCLIP	4	
19	93103-20076-00	OIL SEAL, SW-TYPE	1	
20	90280-04005-00	KEY, WOODRUFF	1	
21	328-17424-00-00	CIRCLIP 1	2	
22	(378-17424-00-00)	CIRCLIP 1	2	
23	93103-40077-00	OIL SEAL	1	
24	328-16111-00-00	GEAR, PRI DRIVE (25T)	1	
25	90282-07023-00	KEY, STRAIGHT	1	
26	214-16119-00-00	SPRING, BELLEVILLE	1	
27	90170-16182-00	NUT	1	

# CLUTCH

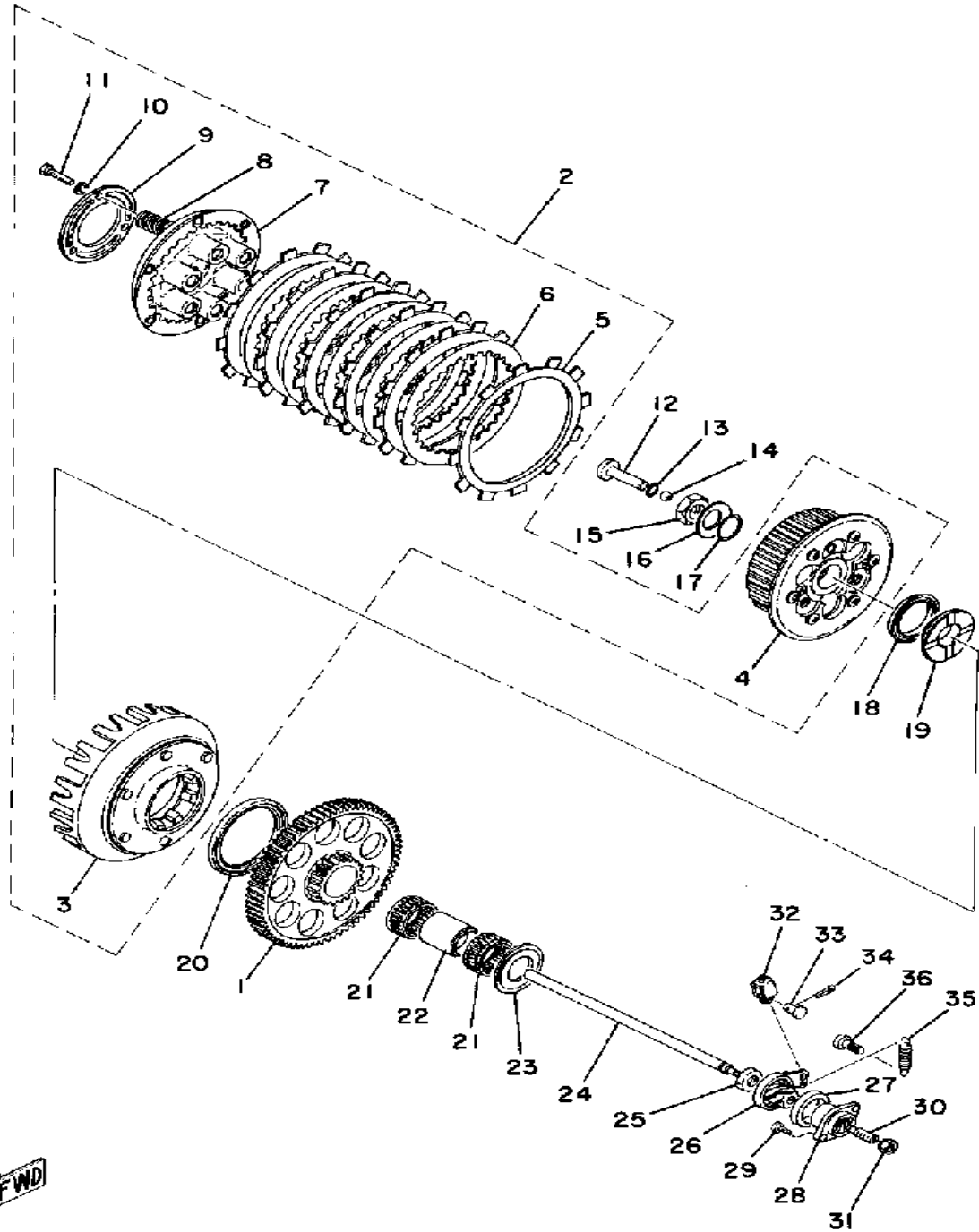

Ref. No.	Part Number	Description	Qty	Remarks
1	(1H3-16170-00-00)	PRI DRVN GEAR .....	1	
2	1H3-16301-10-00	CLUTCH ASSEMBLY .....	1	
3	(1H3-16160-10-00)	BUFFER BOSS ASSEMBLY ...	1	
4	328-16370-10-00	. CLUTCH BOSS ASSEMBLY ..	1	
5	383-16321-10-00	. PLATE, FRICTION .....	6	
6	328-16324-10-00	. PLATE, CLUTCH 1 .....	5	
7	(328-16350-10-00)	PRESSURE PLATE ASSEMBLY	1	
8	90501-23138-00	. SPRING, COMPRESSION ....	6	
9	(328-16352-00-00)	PLATE, PRESSURE 2 .....	1	
10	92995-06100-00	. WASHER, SPRING .....	3	
11	97011-06025-00	. BOLT (97001-06025) .....	3	
12	174-16356-00-00	ROD, PUSH 1 .....	1	
13	93210-09350-00	O-RING .....	1	
14	93505-16006-00	BALL .....	1	
15	90170-18089-00	NUT, HEXAGON .....	1	
16	214-16119-00-00	SPRING, BELLEVILLE .....	1	
17	93210-22298-00	O-RING .....	1	
18	93107-40006-00	OIL SEAL, OS-TYPE .....	1	
19	(328-16182-10-00)	SPACER 2 .....	1	
20	93102-66439-00	OIL SEAL, S-TYPE .....	1	
21	93310-23356-00	BEARING, CYLINDER.# 0 ....	2	
22	278-16181-01-00	SPACER 1 .....	1	
23	360-16154-00-00	PLATE, THRUST 1 .....	1	
24	1H3-16357-00-00	ROD, PUSH 2 .....	1	
25	93109-08061-00	OIL SEAL .....	1	
26	(360-16340-01-00)	PUSH LEVER ASSEMBLY ....	1	
27	214-16347-01-00	SEAL, DUST .....	1	
28	371-16396-00-00	HOUSING, PUSH SCREW ....	1	
29	98580-05012-00	SCREW, PAN HEAD .....	2	

CONTINUED ON NEXT FRAME ►

# CLUTCH

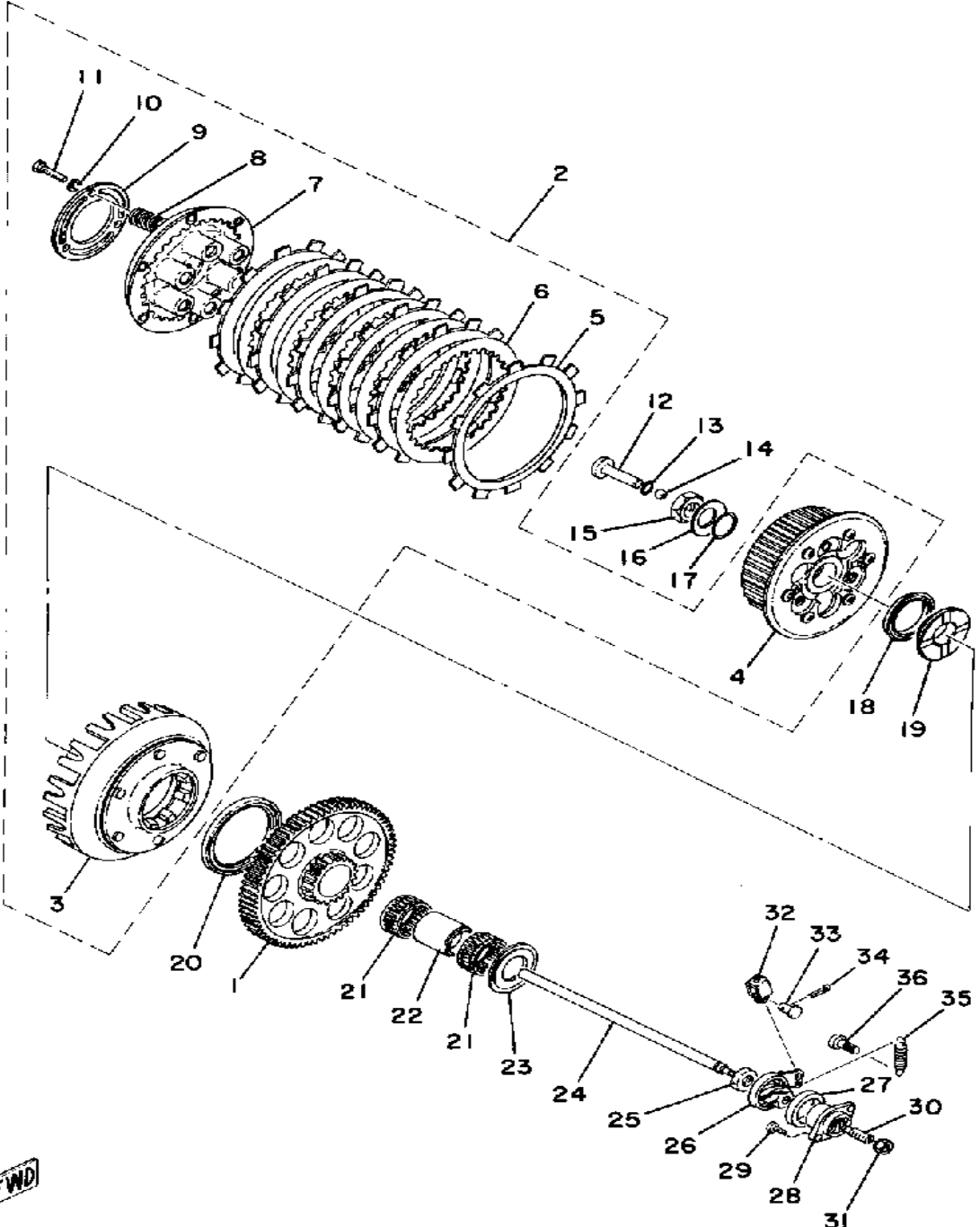

Ref. No.	Part Number	Description	Qty	Remarks
30	90113-08021-00	BOLT, SET .....	1	
31	90179-08179-00	NUT .....	1	
32	214-16389-00-00	JOINT .....	1	
33	90240-06005-00	PIN, CLEVIS .....	1	
34	91401-10015-00	PIN, COTTER .....	1	
35	90506-10069-00	SPRING, TENSION .....	1	
36	132-16346-00-00	HOOK, SPRING .....	1	

# TRANSMISSION

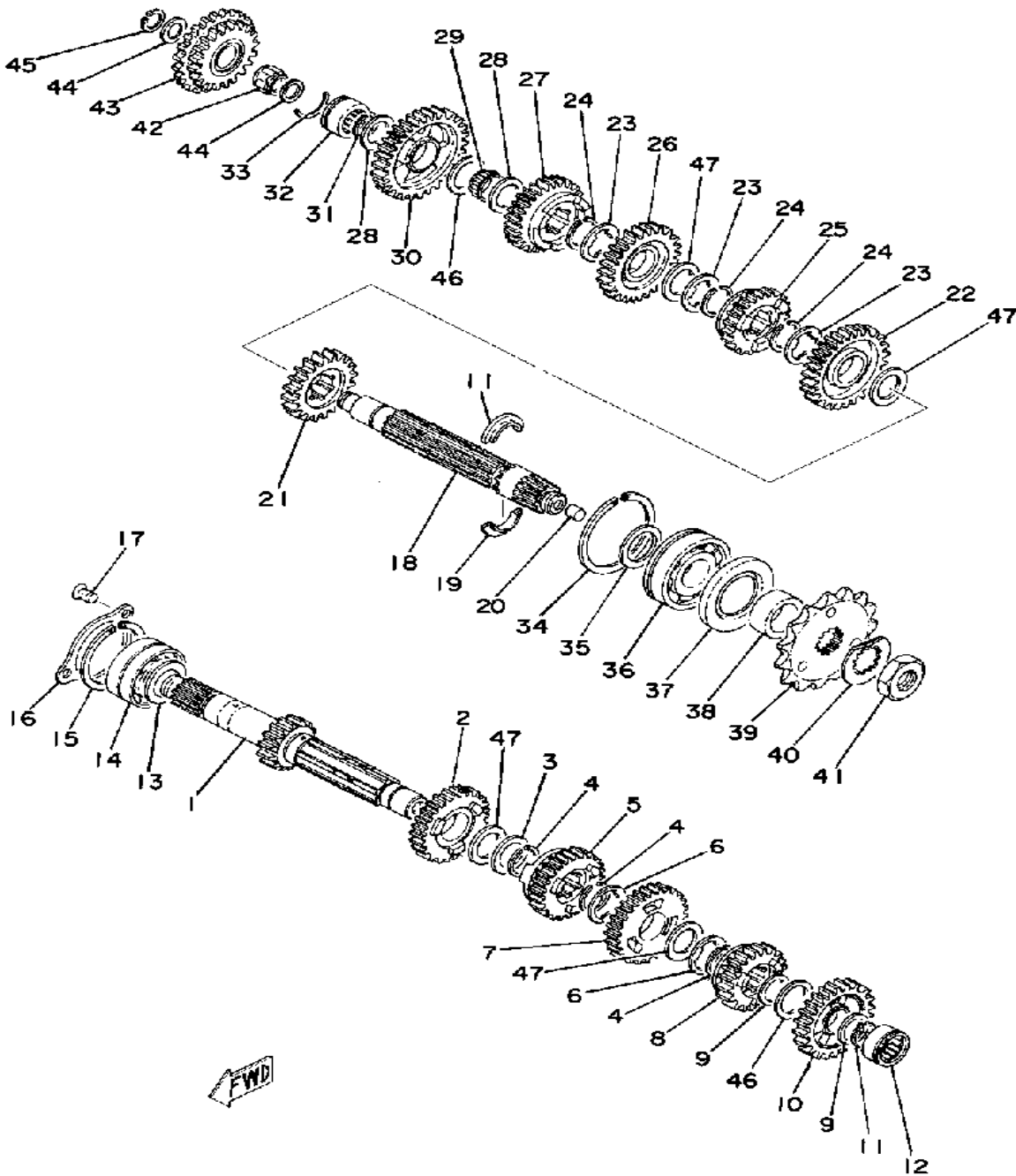

Ref. No.	Part Number	Description	Qty	Remarks
1	328-17411-00-00	AXLE, MAIN	1	
2	(328-17141-00-00)	GEAR, 4TH PINION	1	
3	(90201-15490-00)	WASHER, PLATE	1	
4	93440-25084-00	CIRCLIP	3	
5	328-17131-00-00	GEAR, 3RD PINION	1	
6	90209-21105-00	WASHER	2	
7	(328-17161-00-00)	GEAR, 6TH PINION	1	
8	(328-17121-00-00)	GEAR, 2ND PINION	1	
9	90201-20266-00	WASHER, PLATE (1.0T)	2	
10	(328-17151-00-00)	GEAR, 5TH PINION	1	
11	99009-20400-00	CIRCLIP	1	
12	93311-22027-00	BEARING, CYLINDRICAL	1	
13	168-17428-01-03	SHIM 2 (25-34-0.3)	1	U.R.
	168-17428-01-05	SHIM 2 (25-34-0.5)	1	U.R.
14	93305-20502-00	BEARING (93305-20508-00)	1	
15	93440-52009-00	CIRCLIP	1	
16	360-17471-00-00	PLATE, COVER	1	
17	98701-06014-00	SCREW, FLAT HEAD	3	
18	(328-17421-01-00)	AXLE, DRIVE	1	
19	156-17429-00-00	SPACER, DRIVE AXLE	2	
20	(90336-09002-00)	PLUG, TAPER	1	
21	(328-17251-00-00)	GEAR, 5TH WHEEL	1	
22	(328-17221-00-00)	GEAR, 2ND WHEEL	1	
23	90209-21105-00	WASHER	3	
24	93440-25084-00	CIRCLIP	3	
25	(328-17261-00-00)	GEAR, 6TH WHEEL	1	
26	328-17231-00-00	GEAR, 3RD WHEEL	1	
27	(328-17241-00-00)	GEAR, 4TH WHEEL	1	
28	90201-20276-00	WASHER, PLATE (1.0T)	2	

CONTINUED ON NEXT FRAME ➤



# TRANSMISSION

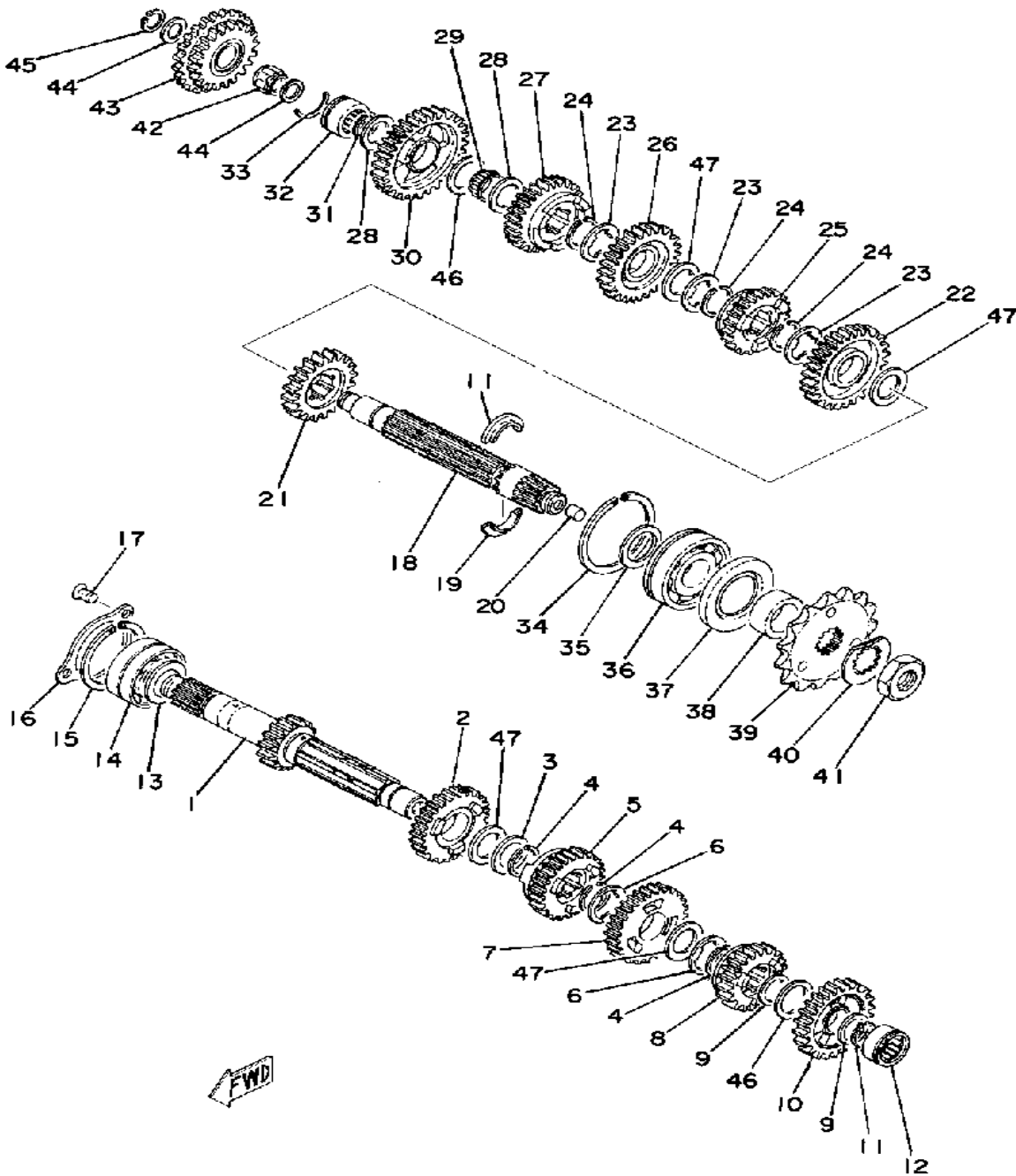

Ref. No.	Part Number	Description	Qty	Remarks
29	(93310-20057-00)	BEARING, CYLINDER.# 0	1	
30	(328-17211-00-00)	GEAR, 1ST WHEEL	1	
31	99009-20400-00	CIRCLIP	1	
32	93311-42045-00	BEARING (20NG3315NE)	1	
33	(378-17425-00-00)	CIRCLIP 2	1	
34	168-17428-01-03	SHIM 2 (25-34-0.3)	1	U.R.
	168-17428-01-05	SHIM 2 (25-34-0.5)	1	U.R.
35	278-17424-01-00	CIRCLIP 1	1	
36	93306-30506-00	BEARING (B6305N) (93306-30504-00)	1	
37	93102-35109-00	OIL SEAL (SD-35-62-6 HS)	1	
38	90387-25192-00	COLLAR	1	
39	(170-17461-80-00)	SPROCKET, DRIVE	1	U.R.
	(170-17461-90-00)	SPROCKET, DRIVE	1	U.R.
	(9383E-17122-00)	SPROCKET, DRIVE	1	U.R.
	170-17461-60-00	SPROCKET, DRIVE	1	U.R.STD
	170-17463-30-00	UNAVAILABLE IN PRICE BOOK (13T)	1	U.R.
	9383E-14056-00	SPROCKET, DRIVE	1	U.R.
	9383E-15083-00	SPROCKET, DRIVE	1	U.R.
40	90215-21022-00	WASHER, LOCK	1	
41	90179-18020-00	NUT	1	
42	(93310-21564-00)	BEARING, CYLINDER.# 0	1	
43	(328-15650-00-00)	IDLE GEAR ASSEMBLY	1	
44	90201-154E8-00	WASHER, PLATE (1.0T)	2	
45	99009-15400-00	CIRCLIP	1	
46	156-17417-00-01	SHIM 1		U.N.
	156-17417-00-02	SHIM 1 (25.1-31-0.2)		U.N.
	156-17417-00-03	SHIM 1		U.N.

CONTINUED ON NEXT FRAME ►

# TRANSMISSION

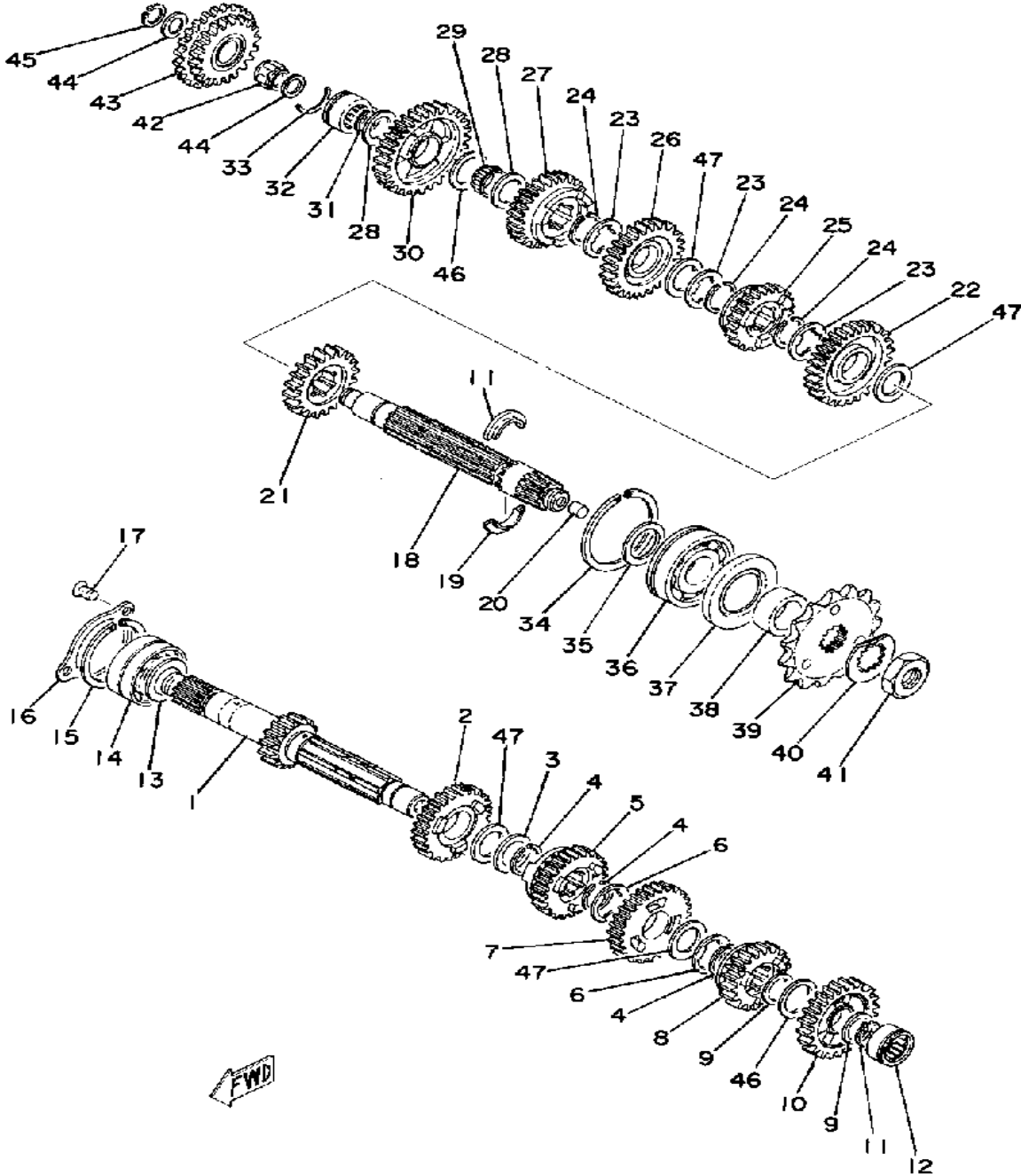

Ref. No.	Part Number	Description	Qty	Remarks
47	328-17427-00-01	SHIM 1 .....		U.N.
	328-17427-00-02	SHIM 1 .....		U.N.
	328-17427-00-03	SHIM 1 .....		U.N.

# SHIFTER 1

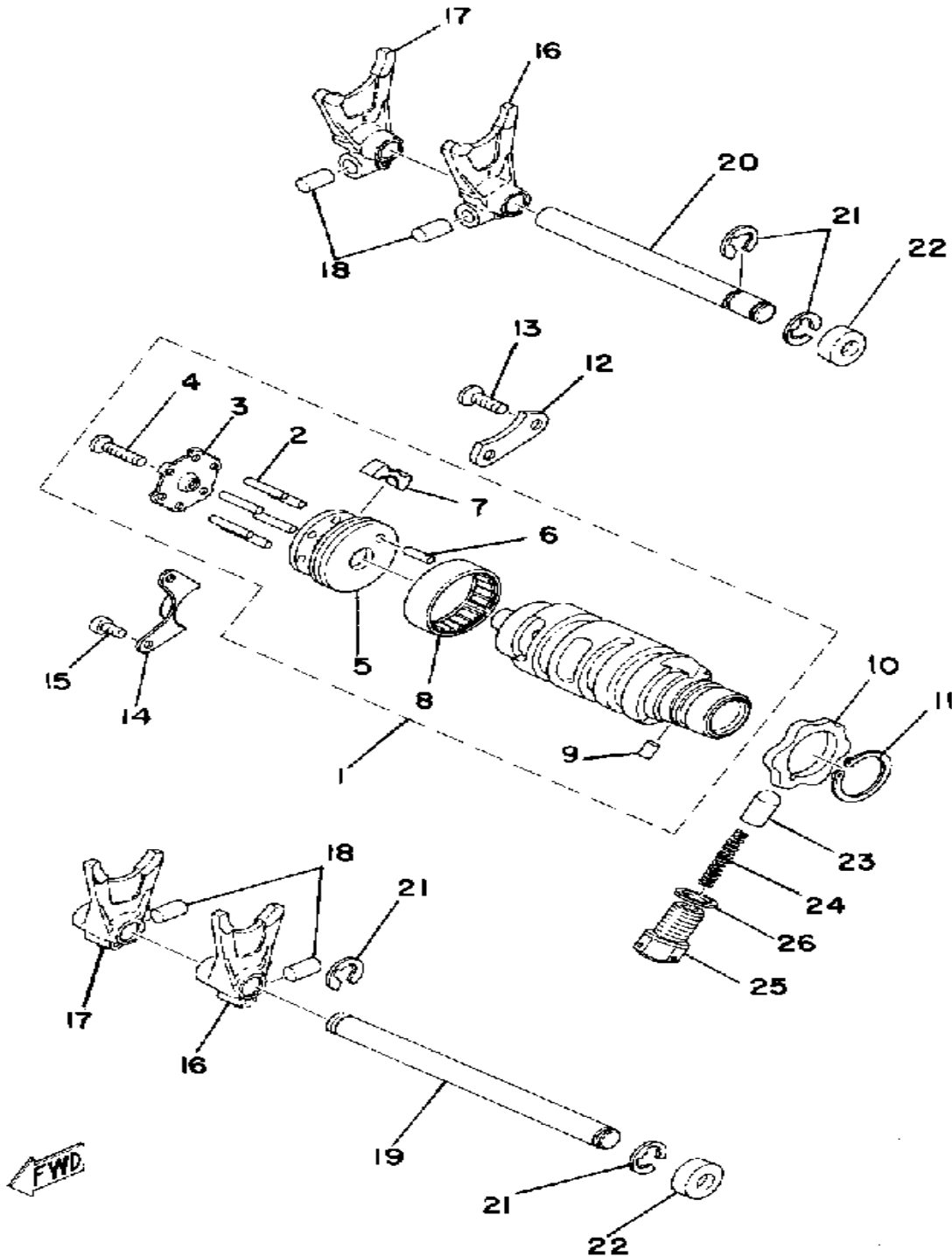

Ref. No.	Part Number	Description	Qty	Remarks
1	(328-18540-10-00)	SHIFT CAM ASSEMBLY	1	
2	93604-22050-00	. PIN, DOWEL	6	
3	328-18561-00-00	. PLATE, SIDE 1	1	
4	98701-05020-00	. SCREW, FLAT HEAD	1	
5	(328-18185-00-00)	SEGMENT	1	
6	93604-14012-00	. PIN, DOWEL	1	
7	(328-18352-10-00)	PLATE, PAWL	1	
8	93315-23612-00	. BEARING	1	
9	93604-08071-00	. PIN, DOWEL	1	
10	(360-18141-00-00)	PLATE, STOPPER	1	
11	99009-30400-00	CIRCLIP	1	
12	(328-18562-00-00)	PLATE, STOPPER 2	1	
13	98701-06014-00	SCREW, FLAT HEAD	2	
14	328-18179-00-00	GUIDE	1	
15	98580-05010-00	SCREW, PAN HEAD	2	
16	328-18511-01-00	FORK, SHIFT 1	2	
17	328-18512-01-00	FORK, SHIFT 2	2	
18	90250-08017-00	PIN, STRAIGHT	4	
19	278-18531-00-00	BAR, SHIF FRK GDE 1	1	
20	(278-18535-00-00)	BAR, SHIF FRK GDE 2	1	
21	99006-10600-00	CIRCLIP	4	
22	90338-22021-00	PLUG, SPEC'L SHAPE (371-18149-00)	2	
23	278-18547-02-00	STOPPER, CAM	1	
24	90501-10062-00	SPRING, COMPRESSION	1	
25	(90149-14066-00)	SCREW, SPEC'L SHAPE	1	
26	214-11198-01-00	GASKET	1	

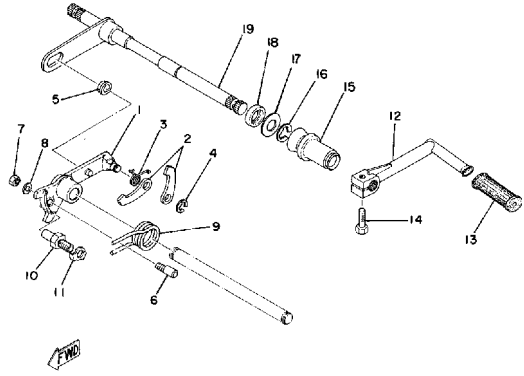

# SHIFTER 2

Ref. No.	Part Number	Description	Qty	Remarks
1	328-18128-00-00	BRACKET	1	
2	(328-18151-00-00)	LEVER, SHIFT 3	2	
3	90508-08007-00	SPRING, TORSION (214-18123-00)	1	
4	99080-07600-00	CIRCLIP (E)	1	
5	214-18178-00-00	ROLLER, SHIFT LEVER	1	
6	90149-06017-00	SCREW, SPEC'L SHAPE (214-18186-00)	1	
7	95380-06600-00	NUT	1	
8	92995-06100-00	WASHER, SPRING	1	
9	90508-32055-00	SPRING, TORSION	1	
10	278-18127-00-00	STOPPER, SCREW	1	
11	90215-08015-00	WASHER, LOCK (214-18139-00)	1	
12	3G2-18111-00-00	PEDAL, SHIFT	1	
13	240-18113-00-00	COVER, SHIFT PEDAL	1	
14	97011-06020-00	BOLT	1	
15	278-18131-00-00	BOOT, SEALING	1	
16	99006-10600-00	CIRCLIP	1	
17	90201-12575-00	WASHER, PLATE	1	
18	93102-12321-00	OIL SEAL, SD-TYPE	2	
19	383-18101-01-00	CHANGE SHAFT ASSEMBLY	1	

# TACHOMETER GEAR

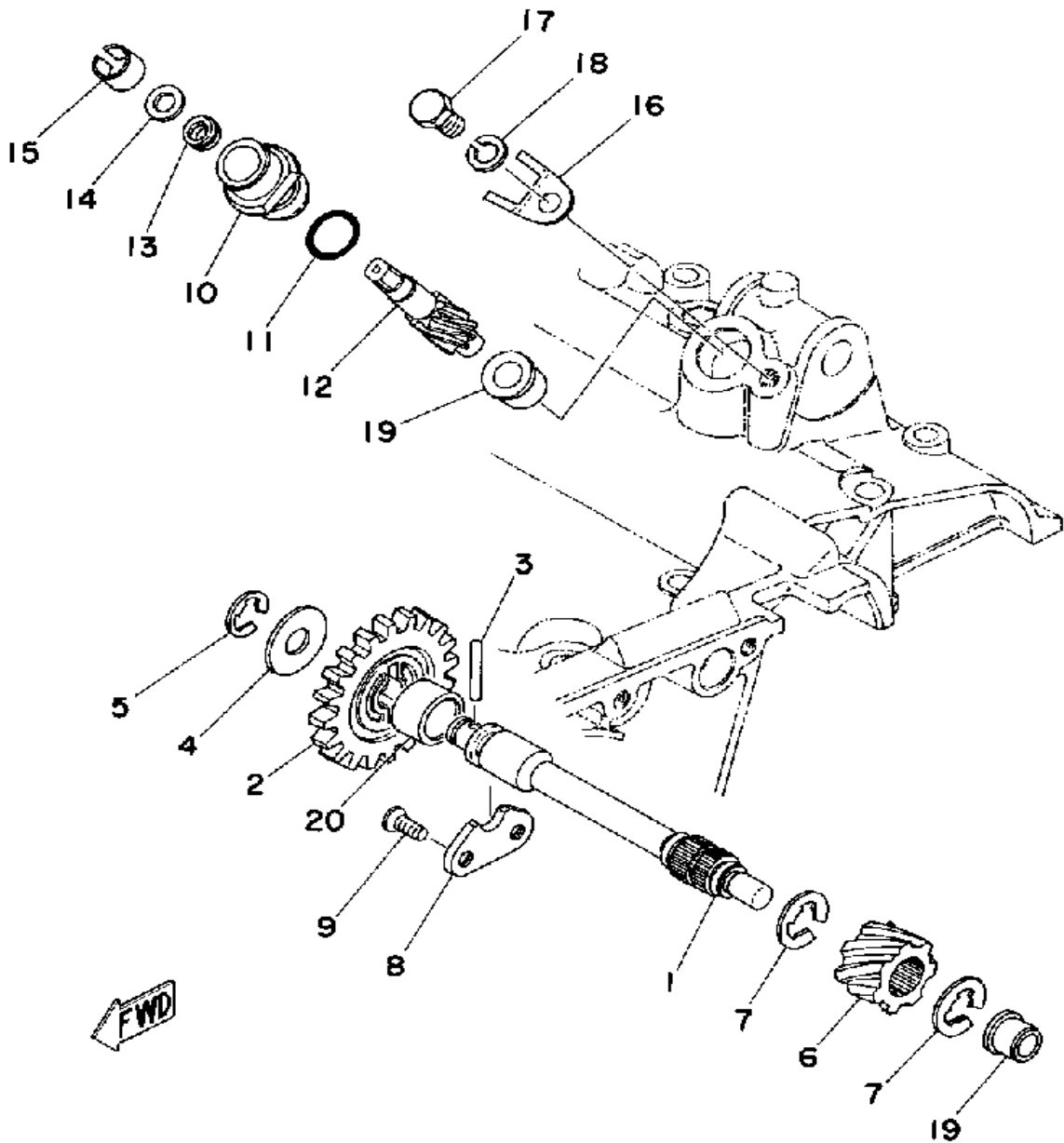

Ref. No.	Part Number	Description	Qty	Remarks
1	(278-17861-00-00)	AXLE, DRIVE GEAR .....	1	
2	(280-17851-00-00)	GEAR, PRIMARY .....	1	
3	93603-22028-00	PIN, DOWEL .....	1	
4	90201-105J4-00	WASHER, PLATE (90201-106H1) .....	1	
5	99001-08600-00	CIRCLIP .....	1	
6	(278-17831-00-00)	GEAR, DRIVE .....	1	
7	99006-10600-00	CIRCLIP .....	2	
8	(278-17812-00-00)	STOPPER .....	1	
9	98701-05012-00	SCREW, FLAT HEAD .....	2	
10	353-17810-00-00	HOUSING ASSEMBLY, TACH (214-17811-01) .....	1	
11	93210-13016-00	O-RING .....	1	
12	214-17841-01-00	GEAR, DRIVEN .....	1	
13	353-17816-00-00	SEAL, HOUSING .....	1	
14	214-17847-00-00	SHIM (7.5-10.8-0.4) .....	1	
15	90383-10005-00	BUSH, FORMED (214-17815-00) 01 .....	1	
16	5U7-17812-00-00	STOPPER .....	1	
17	97011-06010-00	BOLT .....	1	
18	92995-06100-00	WASHER, SPRING .....	1	
19	90381-08002-00	BUSHING (214-17843-00) .....	2	
20	(90380-14040-00)	BUSH, SOLID .....	1	

# WATER PUMP

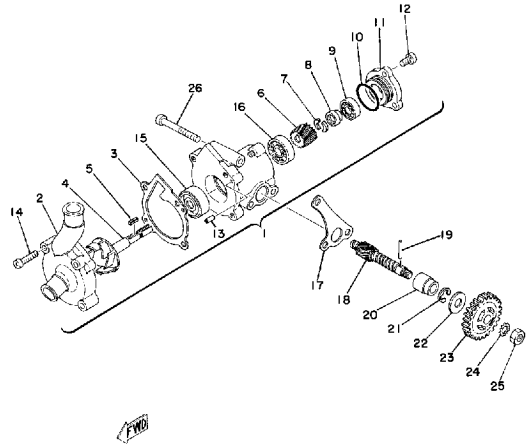

Ref. No.	Part Number	Description	Qty	Remarks
1	(383-12420-00-00)	WATER PUMP ASSEMBLY	1	
2	(383-12422-00-00)	COVER, HOUSING	1	
3	383-12428-00-00	. GASKET, HSNQ CVR 2	1	
4	(383-12450-00-00)	IMPELLER SHAFT ASSEMBLY	1	
5	(90282-03012-00)	KEY, STRAIGHT	1	
6	(383-12459-00-00)	GEAR, IMPELLER SHAF	1	
7	(383-12424-00-00)	PLATE, CRTRGE INNER	2	
8	(383-12423-00-00)	CARTRIDGE, WTR PUMP	1	
9	93300-60814-00	. BEARING (608M4ML01)	1	
10	93210-27ME3-00	. O-RING	1	
11	(383-12432-00-00)	CAP, HOUSING	1	
12	98516-06012-00	. SCREW, PAN HEAD	3	
13	93604-10011-00	. PIN, DOWEL	2	
14	98506-06025-00	. SCREW, PAN HEAD	4	
15	93103-10168-00	. OIL SEAL	1	
16	93306-20005-00	. BEARING (B6200)	1	
17	383-12427-00-00	GASKET, HSNQ CVR 1	1	
18	(383-12436-00-00)	GEAR, DRIVE	1	
19	93603-22028-00	PIN, DOWEL	1	
20	1E7-13176-00-00	METAL, WRM SHAF OTR	1	
21	99001-08600-00	CIRCLIP	1	
22	90201-105J4-00	WASHER, PLATE (90201-106H1)		
23	(329-13178-00-00)	GEAR, PUMP DRIVE	1	
24	92901-08400-00	WASHER, EX.TOOTH	1	
25	95303-08700-00	NUT	1	
26	98506-06050-00	SCREW, PAN HEAD	3	

# RADIATOR

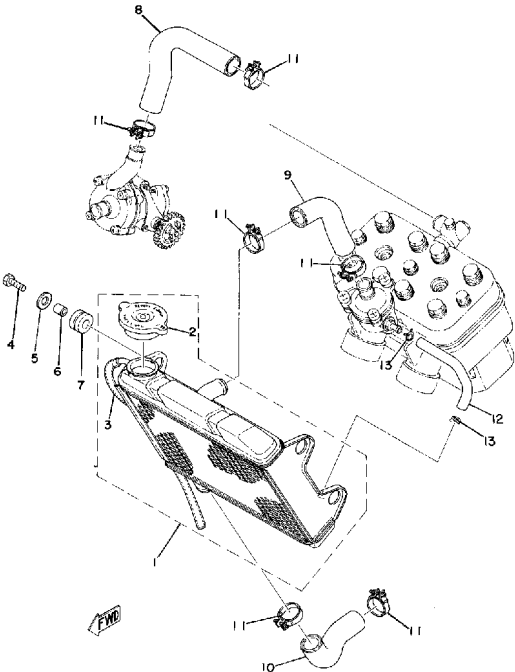

Ref. No.	Part Number	Description	Qty	Remarks
1	(383-12460-01-00)	RADIATOR ASSEMBLY	1	
2	11H-12462-00-00	. CAP, RADIATOR	1	
3	(383-12463-00-00)	PIPE, BREATHER	1	
4	(95201-08025-00)	BOLT, FLAT HD.DRILL	4	
5	(90201-09368-00)	WASHER, PLATE	4	
6	90387-08060-00	COLLAR	4	
7	90480-20131-00	GROMMET	4	
8	(383-12481-00-00)	PIPE 1	1	
9	(3G2-12482-00-00)	PIPE 2	1	
10	(1H3-12484-01-00)	PIPE 4	1	
11	90460-30043-00	CLAMP, HOSE	6	
12	(3G2-12483-00-00)	PIPE 3	1	
13	90460-11002-00	CLAMP, HOSE	2	

# CARBURETOR

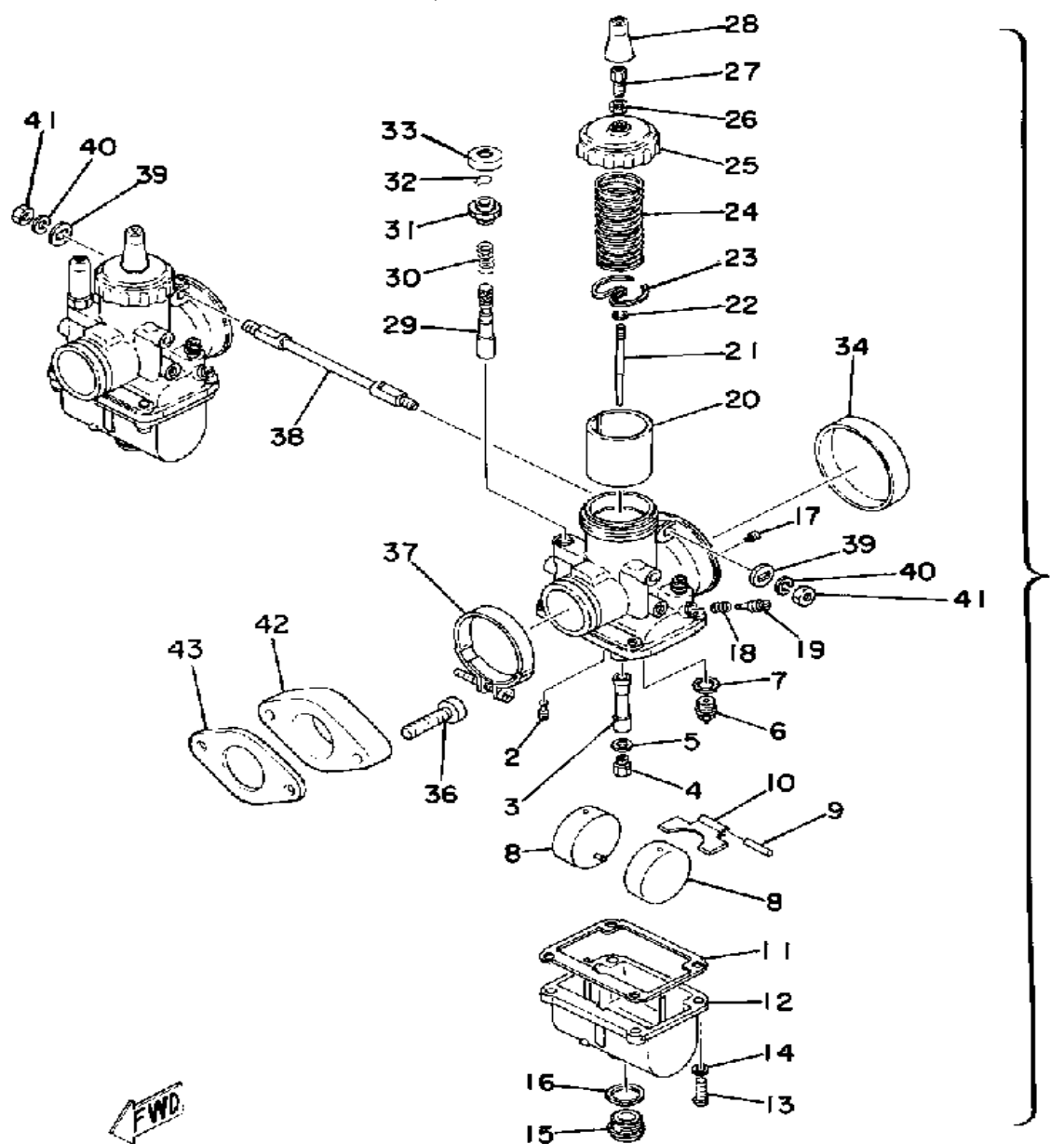

Ref. No.	Part Number	Description	Qty	Remarks
1	(3G2-14101-00-00)	CARBURETOR ASSEMBLY 1	2	
2	193-14142-70-00	. JET, PILOT (# 70)	2	
3	239-14141-32-00	. NOZZLE, MAIN (0-2)	2	
4	137-14143-58-A1	. JET, MAIN (# 290)	2	U.R.
	137-14143-60-A0	. JET, MAIN (# 300)	2	U.R.
	137-14143-62-A1	. JET, MAIN (#310)	2	U.R.STD
	137-14143-64-00	. JET, MAIN (#320)	2	U.R.
	137-14143-66-A1	. JET MAIN, (# 330)	2	U.R.
	137-14143-68-00	. JET, MAIN (#340)	2	U.R.
	137-14143-70-00	. JET, MAIN (#350)	2	U.R.
	137-14143-72-00	. JET, MAIN (#360)	2	U.R.
	137-14143-74-00	. JET, MAIN (#370)	2	U.R.
5	137-14153-00-00	. WASHER, MAIN JET	2	
6	24X-14107-33-00	. NEEDLE VALVE SET (#3.3)	2	
7	239-14195-00-00	. WASHER, NEEDLE VALVE	2	
8	310-14185-00-00	. FLOAT	4	
9	127-14186-00-00	. PIN, FLOAT	2	
10	(239-14187-00-00)	ARM, FLOAT	2	
11	483-14184-00-00	. GASKET, FLOAT CHMBR	2	
12	(239-14181-00-00)	BODY, FLOAT CHMBR 1	2	
13	98580-05016-00	. SCREW, PAN HEAD	8	
14	92990-05100-00	. WASHER, SPRING	8	
15	(239-14115-00-00)	PLUG, SCREW	2	
16	239-14117-00-00	. WASHER, PLUG SCREWS	2	
17	239-14172-00-00	. PILOT JET, AIR	2	
18	127-14134-00-00	. SPRING, AIR ADJUSTING	2	
19	23X-14104-00-00	. AIR SCREW SET	2	
20	(328-14112-30-00)	VALVE, THROTTLE 1	2	

CONTINUED ON NEXT FRAME ➤



# CARBURETOR

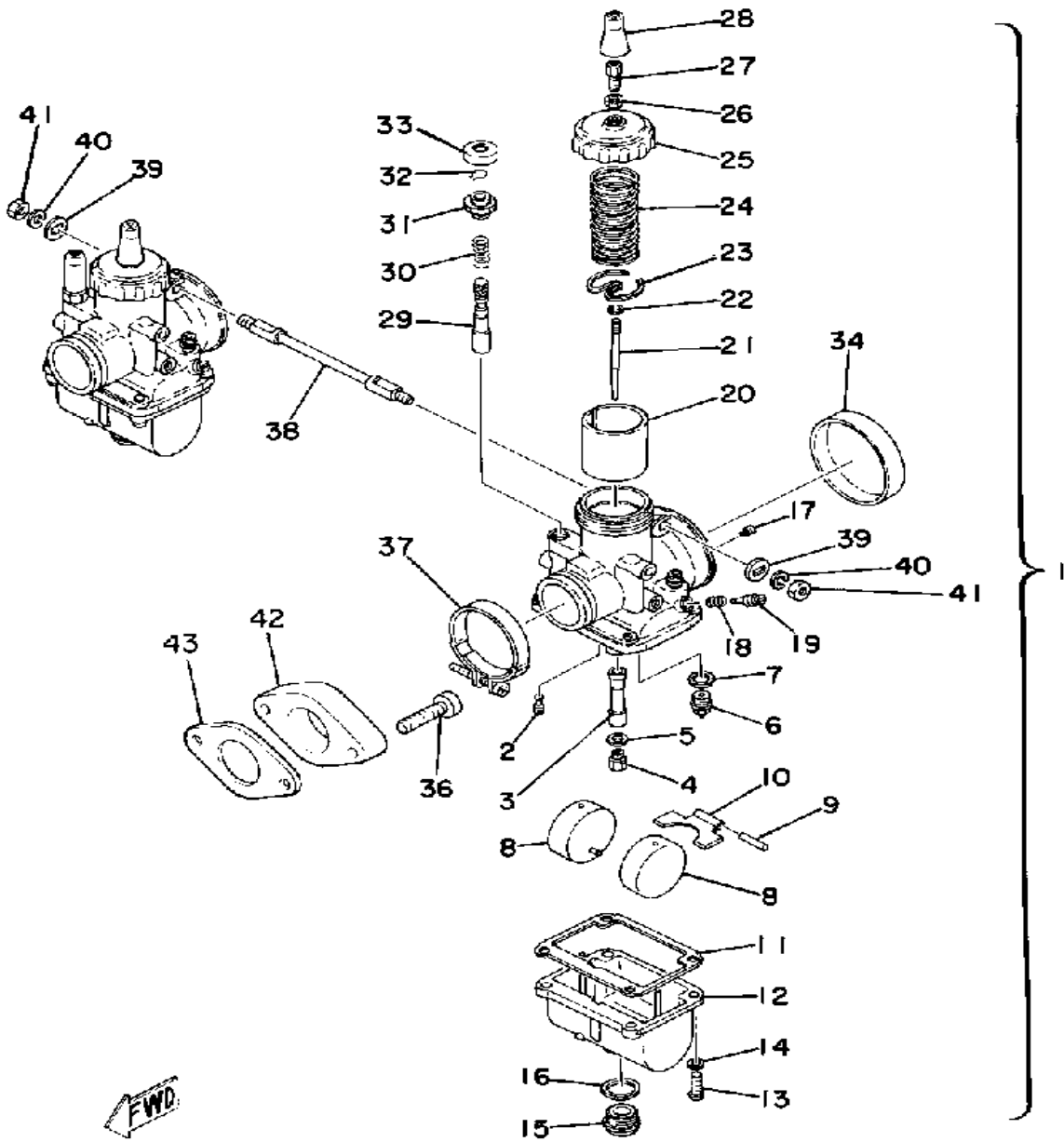

Ref. No.	Part Number	Description	Qty	Remarks
21	239-14116-21-00	. NEEDLE (6F21-3)	2	
22	164-14137-00-00	. CLIP	2	
23	239-14136-00-00	. SEAT, SPRING	2	
24	239-14131-00-00	. SPRING, THRTL VALVE	2	
25	239-14158-00-00	. TOP, MIXING CHAMBER	2	
26	802-14161-00-00	. NUT, CABLE ADJUSTING	2	
27	12G-14106-00-00	. CABLE ADJUST SCREW SET	2	
28	802-14169-00-00	. CAP	2	
29	(1G8-14171-00-00)	PLUNGER, STARTER	2	
30	156-14135-00-00	. SPRING, PLUNGER	2	
31	152-14174-00-00	. CAP, PLUNGER	2	
32	353-14138-00-00	. CLIP, PLUNGER	2	
33	637-14173-00-00	. COVER, PLUNGER CAP	2	
34	240-14157-00-00	COVER, MIXING	2	
35	328-13555-01-00	MANIFOLD, INTAKE	2	
36	91316-08035-00	BOLT, SOCKET HEAD	4	
37	90460-49058-00	CLAMP, HOSE	2	
38	(240-14486-00-00)	SCREW, ROD	1	
39	(90209-10033-00)	WASHER, SPEC'L SHAP	2	
40	92990-06200-00	WASHER	2	
41	95380-06600-00	NUT	2	
42	329-13565-01-00	JOINT, CARBURETOR	2	
43	329-13556-00-00	GASKET, MANIFOLD	2	

# EXHAUST

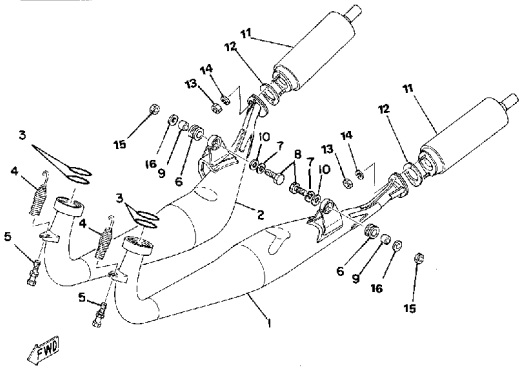
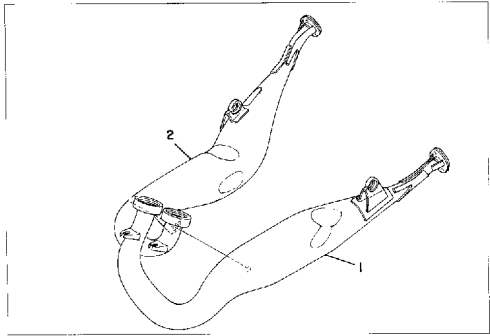

Ref. No.	Part Number	Description	Qty	Remarks
1	(3G2-14610-00-00)	EXHAUST PIPE ASSEMBLY L .	1	
2	(3G2-14620-00-00)	EXHAUST PIPE ASSEMBLY R .	1	
3	93210-48208-00	O-RING . . . . .	4	
4	90507-20012-00	SPRING, TENSION (145-14683-00) . . . . .	2	
5	90109-08305-00	BOLT (322-14684-10) . . . . .	2	
6	565-14747-00-00	DAMPER, MUFFLER . . . . .	2	
7	92990-08100-00	WASHER . . . . .	2	
8	97313-08030-00	BOLT, HEXAGON . . . . .	2	
9	90387-08258-00	COLLAR . . . . .	2	
10	90201-08753-00	WASHER, PLATE . . . . .	2	
11	(3G2-14753-01-00)	SILENCER, EXHAUST . . . . .	1	
12	3G2-14755-01-00	GASKET, SILENCER . . . . .	2	
13	95611-06100-00	NUT, u . . . . .	4	
14	(92911-06100-00)	WASHER, SPRING . . . . .	4	
15	95303-08700-00	NUT . . . . .	2	
16	92901-08600-00	WASHER . . . . .	2	

# C - D - I - MAGNETO

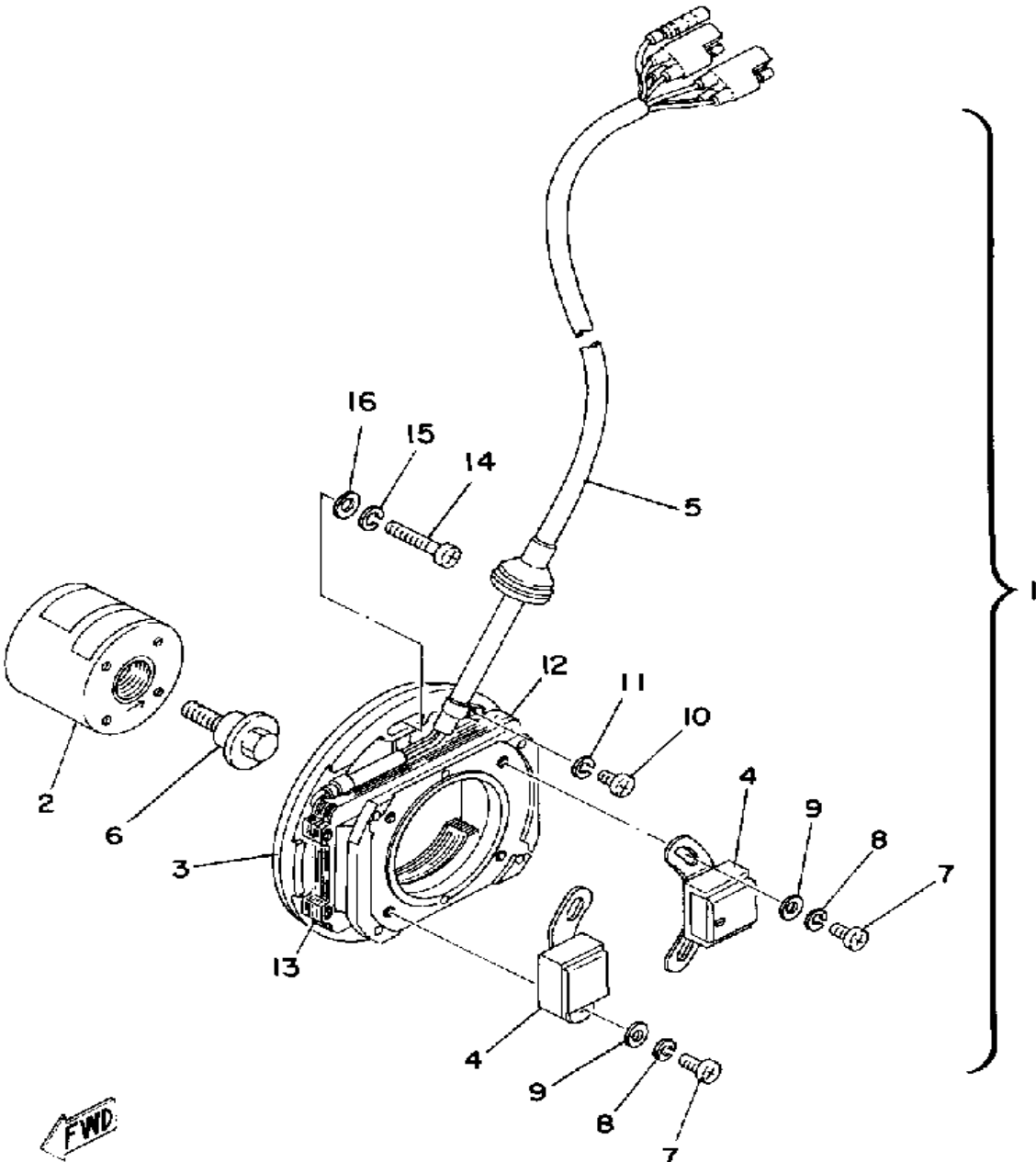

Ref. No.	Part Number	Description	Qty	Remarks
1	(328-85500-11-00)	CDI MAGNETO ASSEMBLY ...	1	EXCEPT EUROPE
2	(328-85550-11-00)	ROTOR ASSEMBLY .....	1	EXCEPT EUROPE
3	(328-85510-11-00)	STATOR ASSEMBLY .....	1	EXCEPT EUROPE
4	364-85543-10-00	. COIL PULSER .....	2	EXCEPT EUROPE
5	(328-85515-10-00)	LEAD WIRE ASSEMBLY .....	1	EXCEPT EUROPE
6	328-85559-10-00	. ROTOR .....	1	EXCEPT EUROPE
7	98580-05010-00	. SCREW, PAN HEAD .....	4	EXCEPT EUROPE
8	92990-05100-00	. WASHER, SPRING .....	4	EXCEPT EUROPE
9	92901-05600-00	. WASHER, PLATE .....	4	EXCEPT EUROPE
10	98580-04008-00	. SCREW, PAN HEAD .....	1	EXCEPT EUROPE
11	92901-04100-00	. WASHER, SPRING .....	1	EXCEPT EUROPE
12	431-85566-10-00	. COIL, CHARGE 1 .....	2	EXCEPT EUROPE
13	431-85567-10-00	. COIL, CHARGE 2 .....	2	EXCEPT EUROPE
14	98580-06030-00	SCREW PAN HEAD .....	2	
15	92995-06100-00	WASHER, SPRING .....	2	
16	92990-06200-00	WASHER .....	2	

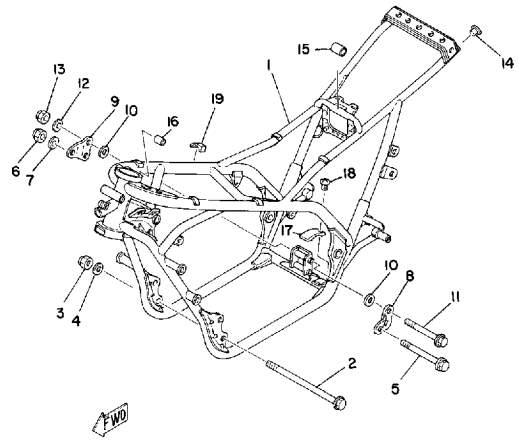

# FRAME

Ref. No.	Part Number	Description	Qty	Remarks
1	(3G2-21110-01-33)	FRAME .....	1	
2	90105-08034-00	BOLT, WASHER BASED .....	2	M8-240L
3	90185-08089-00	NUT, SELF-LOCKING .....	2	
4	92901-08600-00	WASHER .....	2	
5	90101-10313-00	BOLT .....	1	M10-140L
6	90185-10060-00	NUT, SELF-LOCKING .....	1	
7	92990-10600-00	WASHER, PLATE .....	1	
8	1H3-21314-00-00	STAY, ENGINE 1 .....	1	
9	(1H3-21317-00-00)	STAY, ENGINE 4 .....	1	
10	92990-08200-00	WASHER, PLAIN .....	4	
11	95811-08075-00	BOLT, FLANGE .....	2	
12	92901-08600-00	WASHER .....	2	
13	90185-08089-00	NUT, SELF-LOCKING .....	2	
14	(90339-12003-00)	PLUG .....	2	
15	3G2-24182-00-00	DAMPER, LOCATING 2 .....	2	
16	(3G2-24181-00-00)	DAMPER, LOCATING 1 .....	2	
17	(3G2-2117G-00-00)	PROTECTOR .....	1	
18	98703-05010-00	SCREW, FLAT HEAD (98602-05010) .....	1	
19	240-24181-00-00	DAMPER, LOCATING 1 .....	6	

# REAR ARM

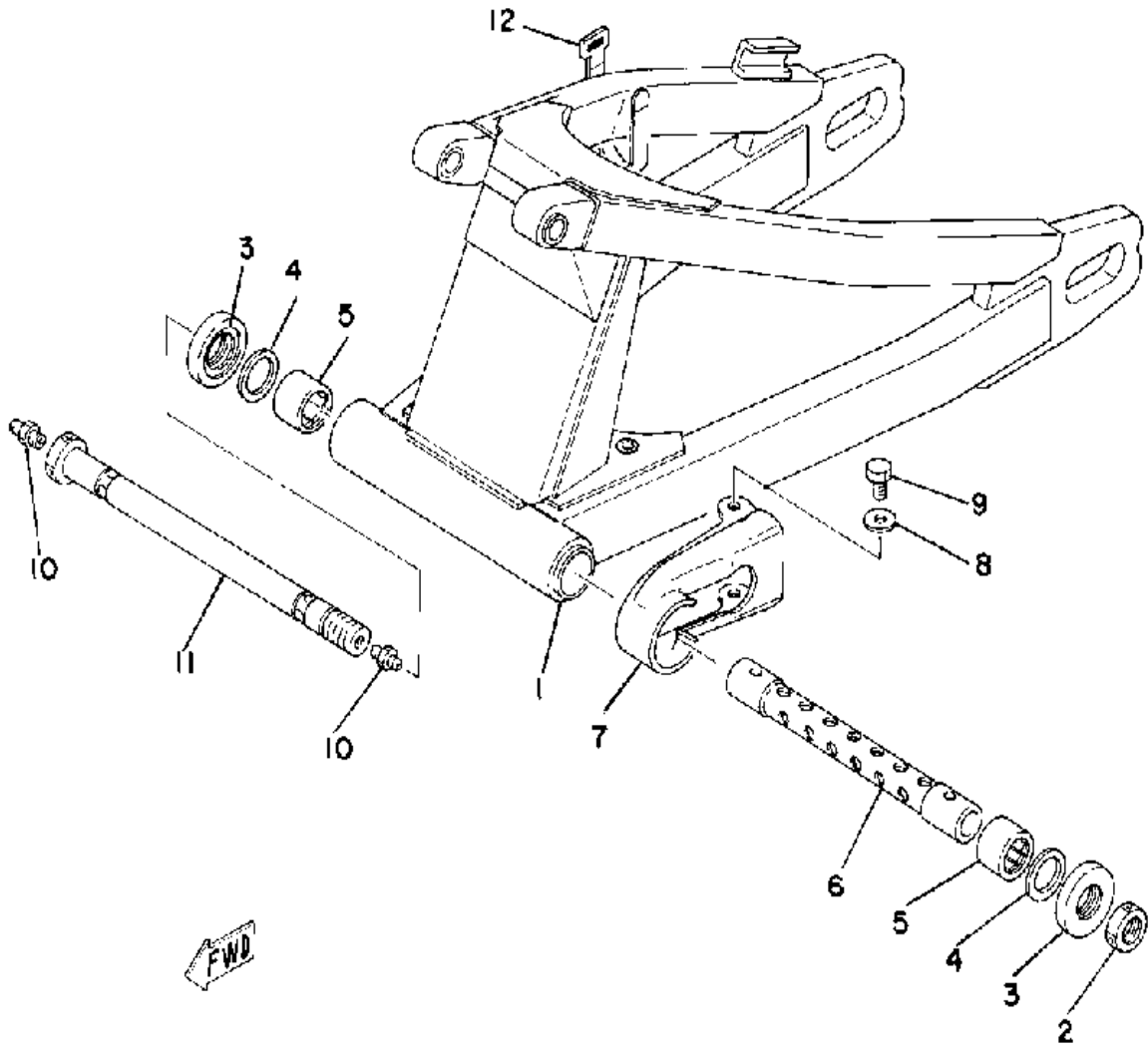

Ref. No.	Part Number	Description	Qty	Remarks
1	(3G2-22110-00-35)	REAR ARM	1	
2	90179-16028-00	NUT, SPEC'L SHAPE	1	
3	93342-22205-00	BEARING, FLAT # 2	2	
4	648-45533-00-02	SHIM (90201-22284)	1	
5	93317-22208-00	BEARING, CYLINDER.# 7	2	
6	1H3-22124-00-00	BUSH 2	1	
7	3G2-22151-00-00	SEAL, GUARD	1	
8	90209-06064-00	WASHER, SPEC'L SHAP (812-82327-00) 0 1	2	
9	97013-06012-00	BOLT	2	
10	93700-06M03-00	NIPPLE, GREASE	2	
11	(1H3-22141-00-00)	SHAFT, PIVOT	1	
12	447-82591-00-00	BAND, SWITCH CORD	1	

# REAR CUSHION

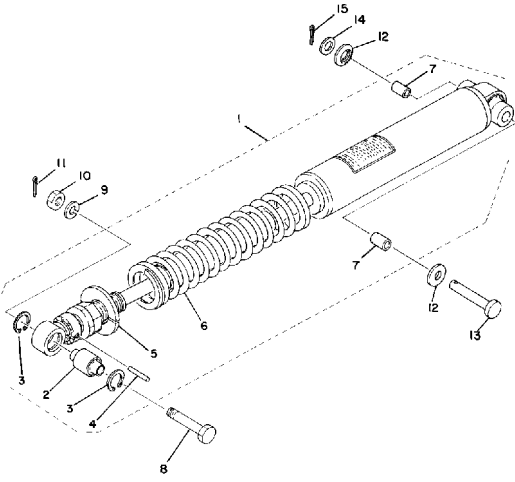

Ref. No.	Part Number	Description	Qty	Remarks
1	(3G2-22210-00-00)	SHK/ABS ASSEMBLY, REAR	1	
2	(3G2-22216-00-00)	BUSH, RR SHOCK ABS	1	
3	(93450-24062-00)	CIRCLIP, INNER	2	
4	93604-26132-00	. PIN, DOWEL	1	
5	(3G2-22214-00-00)	GUIDE, SPRING 1	2	
6	(90501-85544-00)	SPRING, COMPRESSION	1	
7	90380-12051-00	. BUSH, SOLID	2	
8	(90109-12434-00)	BOLT	1	
9	92901-12100-00	WASHER, SPRING	1	
10	95301-12700-00	NUT (95302-12700)	1	
11	91401-25030-00	PIN, COTTER	1	
12	1W1-22128-00-00	COVER, THRUST 1	2	
13	90240-12059-00	PIN, CLEVIS	1	
14	92990-12600-00	WASHER, PLATE	1	
15	91401-30030-00	PIN, COTTER	1	

# BRAKE PEDAL - MASTER CYLINDER

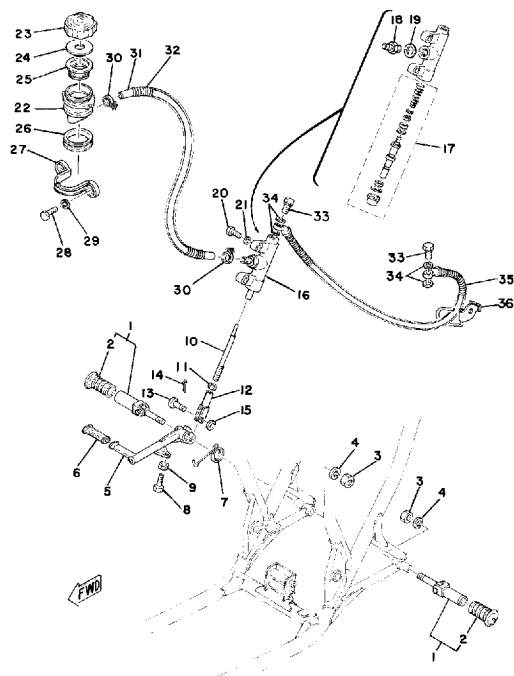

Ref. No.	Part Number	Description	Qty	Remarks
1	5F6-27410-10-00	FRT FOOTREST ASSEMBLY L	2	
2	240-27413-00-00	. COVER, FOOTREST	2	
3	(90179-10173-00)	NUT, SPEC'L SHAPE	2	
4	92901-10100-00	WASHER, SPRING	2	
	92990-10100-00	WASHER, SPRING	2	
5	(1H3-27211-00-00)	PEDAL, BRAKE	1	
6	240-18113-00-00	COVER, SHIFT PEDAL	1	
7	(90508-23304-00)	SPRING, TORSION	1	
8	90101-06288-00	BOLT	1	
9	95380-06700-00	NUT	1	
10	(3G2-27231-00-00)	ROD, BRAKE	1	
11	95303-08700-00	NUT	1	
12	(409-27222-00-00)	JOINT	1	
13	(90249-08085-00)	PIN, SPEC'L SHAPE	1	
14	91490-20020-00	PIN, COTTER	1	
15	99009-06600-00	CIRCLIP	1	
16	(409-25850-50-00)	MSTR CYLINDER ASSEMBLY	1	
17	409-W0042-50-00	. CYLINDER KIT, MASTER	1	
18	(409-25899-50-00)	BOLT, UNION	1	
19	(409-25898-50-00)	GASKET	1	
20	(95201-08030-00)	BOLT, FLAT HD.DRILL	2	
21	92990-08100-00	WASHER	2	
22	(1H3-25894-00-00)	TANK, RESERVOIR	1	
23	2KF-25852-50-00	CAP, RESERVOIR	1	
24	2GU-25855-00-00	BUSH, DIAPHRAGM	1	
25	360-25854-00-00	DIAPHRAGM, RESERVOIR	1	
26	(1H3-25897-00-00)	DAMPER	1	
27	(3G2-25874-00-00)	HOSE, BRAKE	2	
28	97011-06020-00	BOLT	2	

CONTINUED ON NEXT FRAME ➤

# BRAKE PEDAL - MASTER CYLINDER

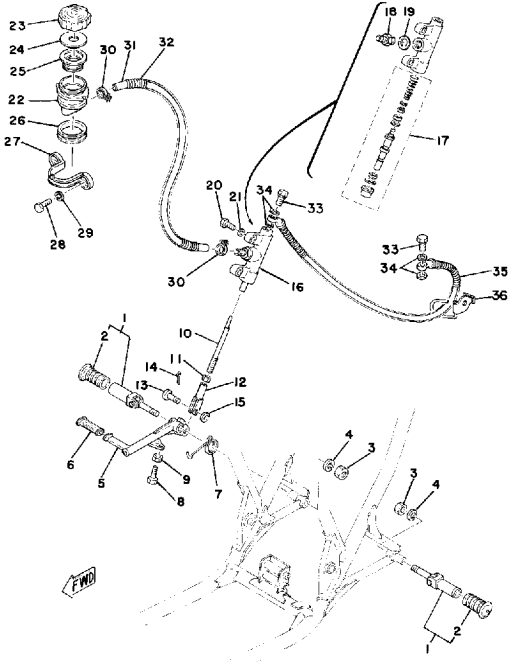

Ref. No.	Part Number	Description	Qty	Remarks
29	92995-06100-00	WASHER, SPRING	2	
30	90601-11525-00	CLAMP, HOSE	2	
31	(90445-15324-00)	HOSE	1	
32	(90504-10022-00)	SPRING, COMPRESSION	1	
33	90401-10034-00	BOLT, UNION	2	
34	90201-10118-00	WASHER, PLATE	4	
35	(409-25872-54-00)	HOSE, BRAKE 1	1	
36	(3G2-25875-00-00)	HOLDER, BRKE HOSE 1	1	



# FRONT FENDER - REAR FENDER

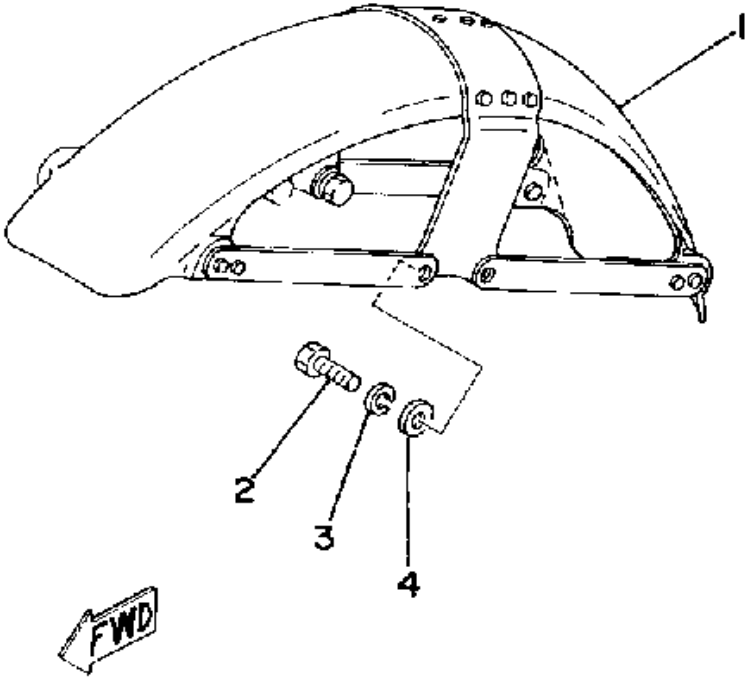
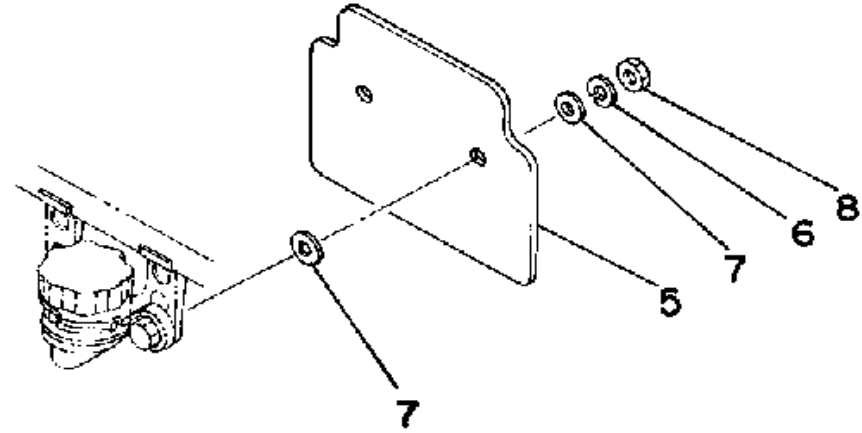

Ref. No.	Part Number	Description	Qty	Remarks
1	29L-21510-00-E1	FENDER, FRONT .....	1	CHAPPY RED
2	97001-08025-00	BOLT (1NV) .....	1	
3	92990-08100-00	WASHER .....	4	
4	92901-08600-00	WASHER .....	4	
5	(3G2-21629-00-00)	GUARD, MUD .....	1	
6	92995-06100-00	WASHER, SPRING .....	2	
7	90201-06057-00	WASHER, PLATE .....	4	
8	95380-06700-00	NUT .....	2	

# FRONT FORK

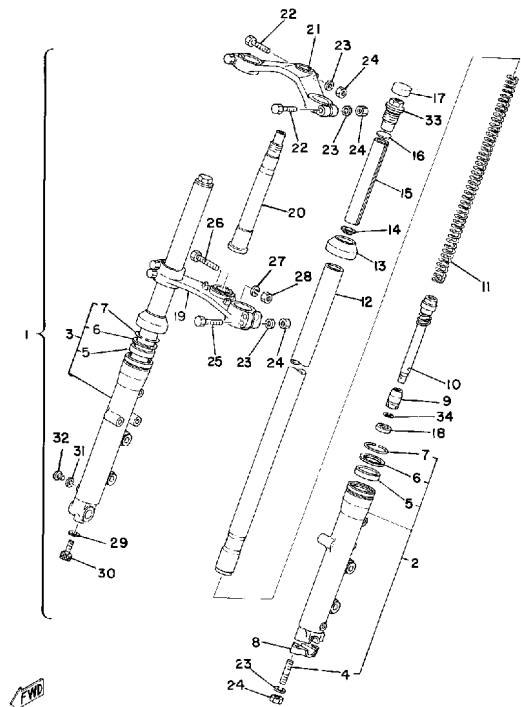

Ref. No.	Part Number	Description	Qty	Remarks
1	(3G2-23101-01-00)	FRONT FORK ASSEMBLY	1	
2	(3G2-23126-01-00)	TUBE, OUTER 1	1	
3	(3G2-23136-01-00)	TUBE, OUTER 2	1	
4	90116-08261-00	. BOLT, STUD	2	
5	4G0-23145-00-00	. OIL SEAL	1	
6	341-23146-50-00	. WASHER, OIL SEAL	1	
7	341-23156-50-00	. CLIP, OIL SEAL	1	
8	341-23167-50-00	. HOLDER, AXLE	1	
9	(3G2-23173-00-00)	SPINDLE, TAPER	2	
10	(3G2-23170-01-00)	CYLINDER, FRTRFK	2	
11	(3G2-23141-02-00)	SPRING, FRONT FORK	2	
12	(3G2-23124-00-00)	TUBE, INNER 1	2	
13	1T3-23144-50-00	SEAL, DUST	2	
14	583-23142-00-00	. SEAT, SPRING UPPER	2	
15	11H-23118-00-00	. SPACER	2	
16	2H7-23149-00-00	. WASHER, SPRING UPR	2	
17	2F0-23168-00-00	. CAP, FRONT FORK	2	
18	(3G2-23184-00-00)	CAP, AIR VALVE	2	
19	(3G2-23340-00-00)	UNDER BRACKET	1	
20	(3G2-23341-00-00)	SHAFT, STEERING	1	
21	(1H3-23435-00-00)	CROWN, HANDLE	1	
22	90101-08263-00	. BOLT	3	
23	92901-08600-00	. WASHER	9	
24	90185-08089-00	. NUT, SELF-LOCKING	9	
25	(97281-08055-00)	BOLT, FLAT HEAD	4	
26	(322-23356-00-00)	BOLT 2	1	
27	92901-10100-00	. WASHER, SPRING	1	
	92990-10100-00	. WASHER, SPRING	1	
28	(322-23357-00-00)	NUT	1	

CONTINUED ON NEXT FRAME ►

# FRONT FORK

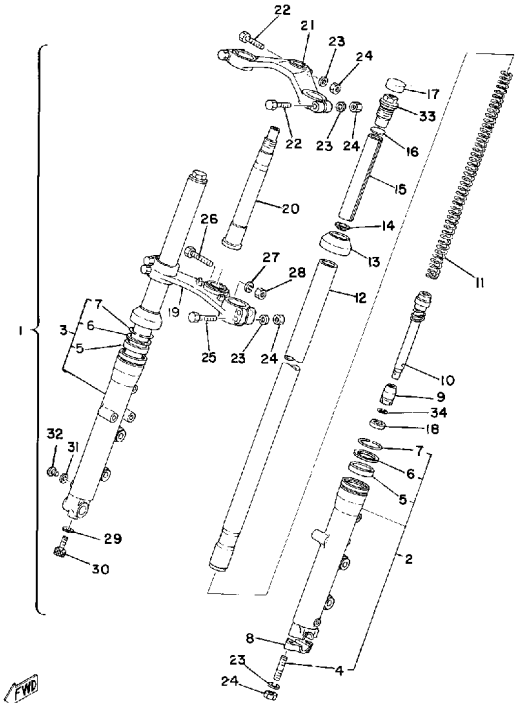

Ref. No.	Part Number	Description	Qty	Remarks
29	509-23158-L0-00	. GASKET .....	2	
30	278-23181-50-00	. BOLT, HEXAGON SOCKET HEAD .....	2	
31	122-23129-00-00	. GASKET, DRAIN PLUG .....	2	
32	4H7-23119-00-00	. PLUG, DRAIN - (122-23119-01)	2	
	98580-04008-00	. SCREW, PAN HEAD .....	2	
33	(3G2-23111-00-00)	BOLT, CAP .....	2	
34	(3G2-23183-00-00)	CIRCLIP .....	2	

# STEERING

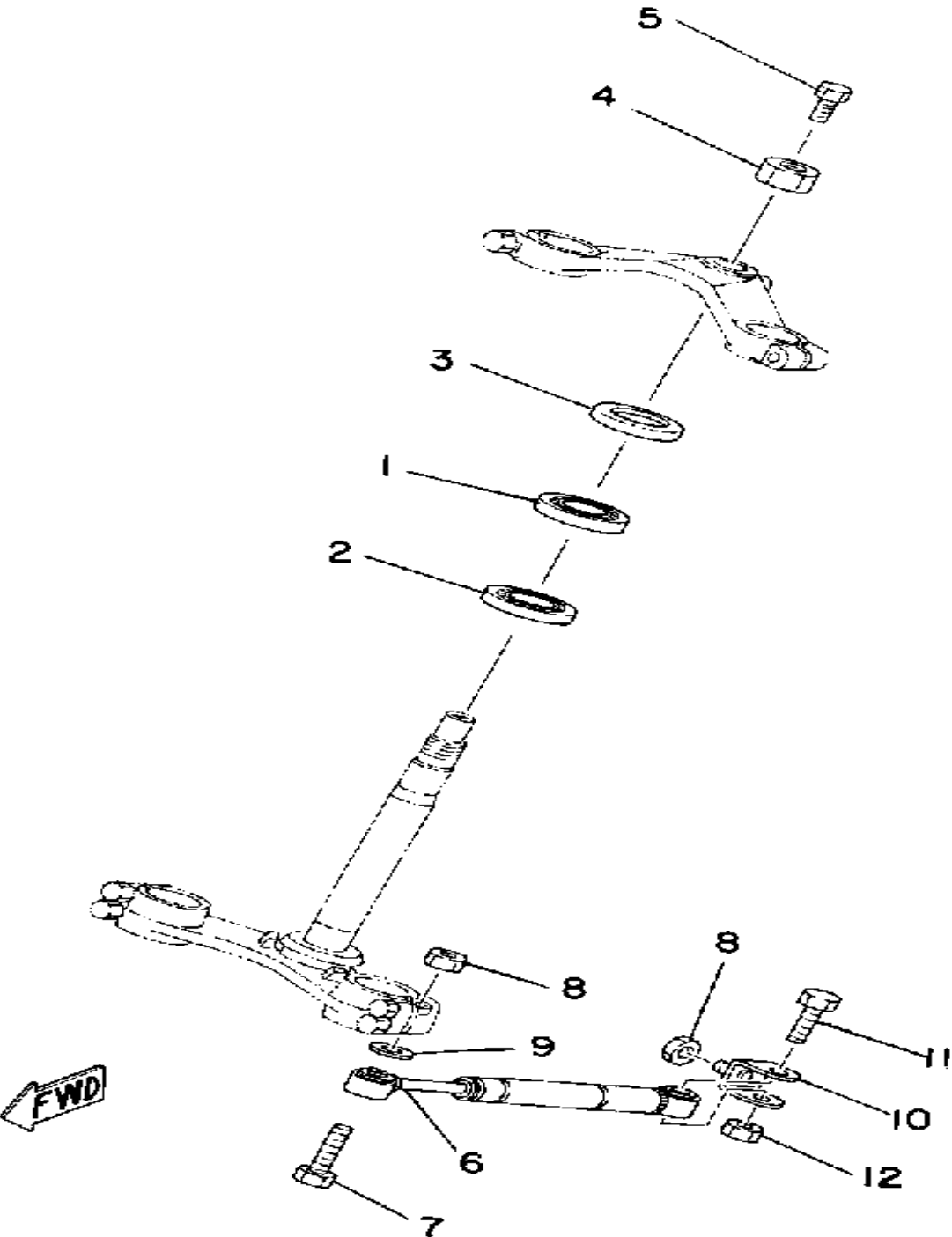

Ref. No.	Part Number	Description	Qty	Remarks
1	93332-00001-00	BEARING .....	1	
2	93332-00008-00	BEARING .....	1	
3	1J7-23415-00-00	COVER, BALL RACE 1 .....	1	
4	90179-25033-00	NUT .....	1	
5	90105-14102-00	BOLT, WASHER BASED .....	1	
6	(240-23490-00-00)	HDLBR SMY DMPR ASSEMBLY	1	
7	90101-08699-00	BOLT .....	1	
8	95611-08100-00	NUT, U .....	2	
9	92990-08200-00	WASHER, PLAIN .....	1	
10	59W-23491-00-00	JOINT .....	1	
11	97313-08030-00	BOLT, HEXAGON .....	1	
12	95303-08700-00	NUT .....	1	

# HANDLE - WIRE

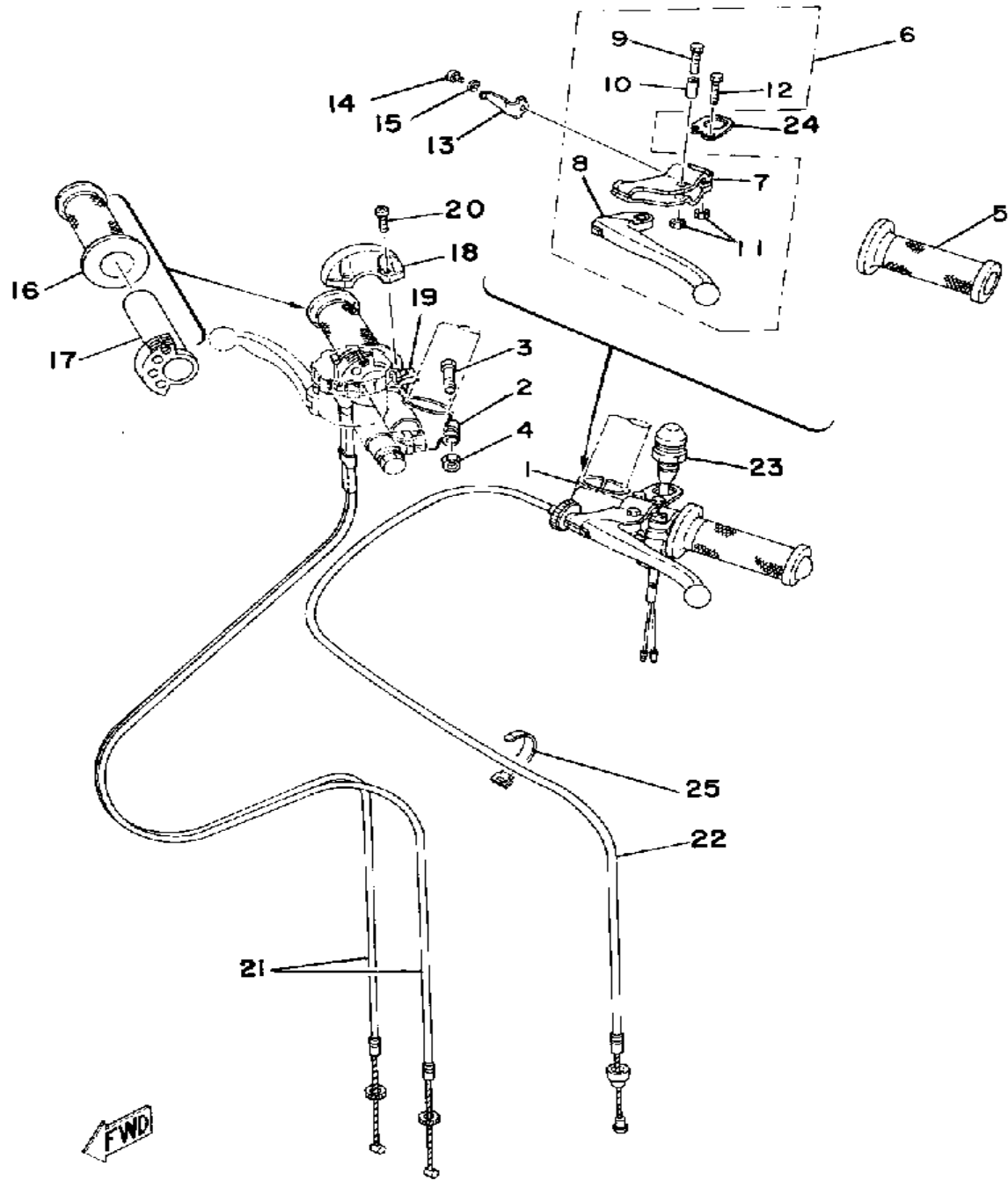

Ref. No.	Part Number	Description	Qty	Remarks
1	409-26121-01-00	HANDLEBAR LH	1	
2	409-26122-01-00	HANDLEBAR RH	1	
3	97313-08035-00	BOLT, HEXAGON	2	
4	95611-08100-00	NUT, U	2	
5	47X-26241-00-00	GRIP (LEFT)	1	
6	240-82810-00-00	LEVER HOLDER ASSEMBLY 1	1	
7	(240-82811-00-00)	HOLDER, LEVER 1	1	
8	150-83912-00-38	. LEVER L	1	
9	97023-06020-00	. BOLT (3XF)	1	
10	214-83913-00-00	. COLLAR, LEVER 1	1	
11	95380-06700-00	. NUT	3	
12	97011-06025-00	. BOLT (97001-06025)	2	
13	92995-06100-00	WASHER, SPRING	1	
14	5F6-26368-00-00	SPRING, LOCK	1	
15	98501-05008-00	SCREW, PAN HEAD	1	
	98580-05010-00	SCREW, PAN HEAD	1	
16	47X-26242-00-00	GRIP (RIGHT)	1	
17	(3G2-26243-00-00)	TUBE, THRTL GUIDE	1	
18	3G2-26281-01-00	CAP, GRIP UPPER	1	
19	3G2-26282-01-00	CAP, GRIP LOWER	1	
20	98511-05020-00	SCREW, PAN HEAD	2	
	98580-05020-00	SCREW, PAN HEAD	2	
21	3G2-26311-00-00	CABLE, THROTTLE 1	2	
	3G3-26311-00-00	UNAVAILABLE IN PRICE BOOK	1	
22	3G2-26335-00-00	CABLE, CLUTCH	1	
23	(3G2-83976-00-00)	SWITCH, HANDLE 1	1	
24	(294-83974-00-00)	HOLDER, HANDLE SWCH	1	
25	341-26397-01-00	BAND	1	

# MASTER CYLINDER - BRAKE HOSE

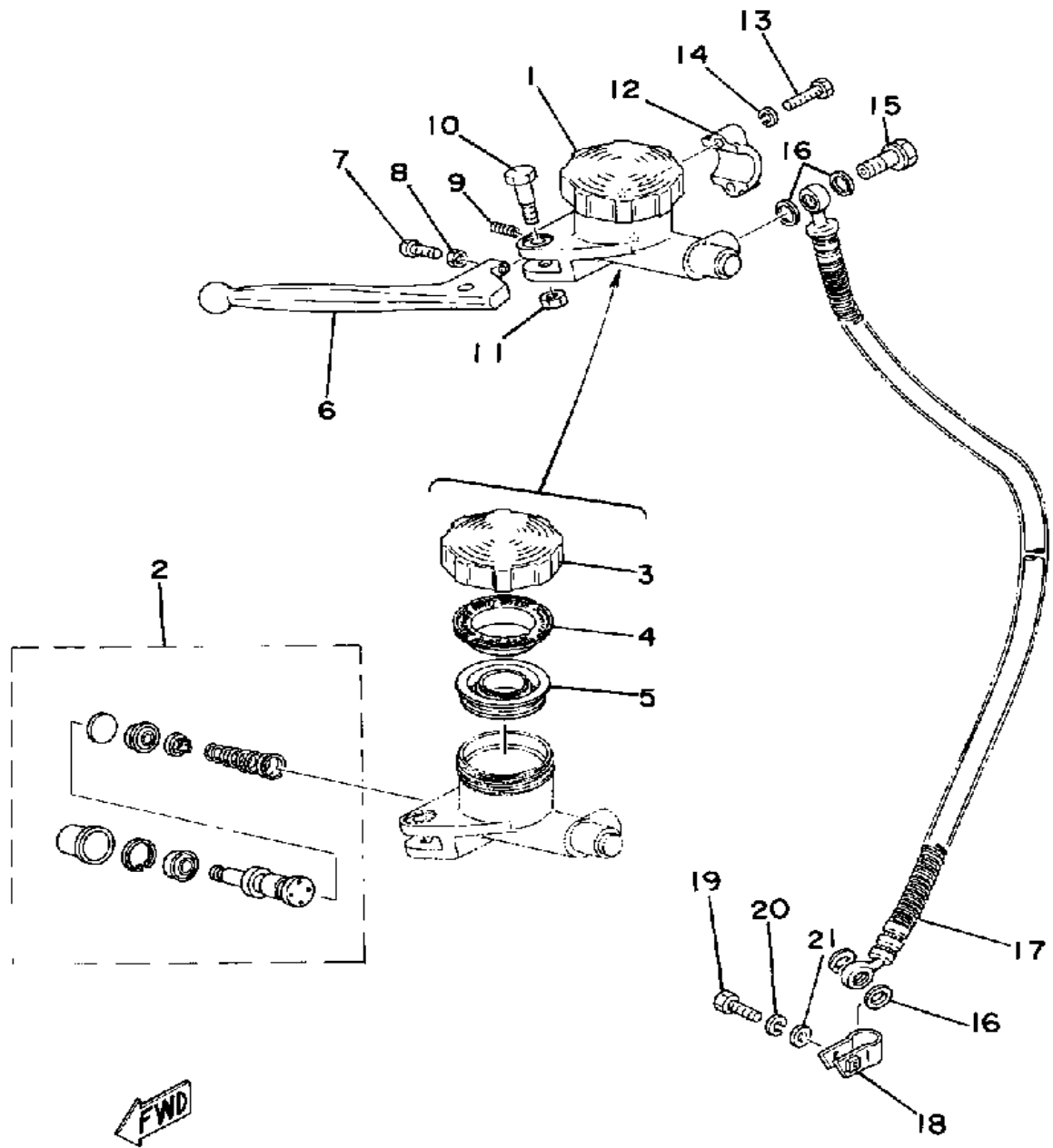

Ref. No.	Part Number	Description	Qty	Remarks
1	(1H3-25850-00-00)	MSTR CYLINDER ASSEMBLY	1	
2	(1H3-20000-10-00)	CYLINDER KIT MASTE	1	
3	(409-25852-00-00)	CAP, RESERVOIR	1	
4	(409-25855-00-00)	BUSH, DIAPHRAGM	1	
5	(409-25854-00-00)	DIAPHRAGM RESERVOR	1	
6	(341-83922-00-00)	LEVER R	1	
7	90149-06131-00	SCREW	1	
8	90170-06010-00	NUT	1	
9	90501-10312-00	SPRING, COMPRESSION	1	
10	90109-06465-00	BOLT	1	
11	95380-06700-00	NUT	1	
12	1J3-25867-00-00	BRACKET, MASTER CYLINDER (341-25867-00)	1	
13	97011-06025-00	BOLT (97001-06025)	2	
14	92995-06100-00	WASHER, SPRING	2	
15	90401-10034-00	BOLT, UNION	1	
16	90201-10118-00	WASHER, PLATE	4	
17	(3G2-25873-00-00)	HOSE, BRAKE 2	1	
18	(2R8-25876-00-00)	HOLDER, BRKE HOSE 2	1	
19	97011-06025-00	BOLT (97001-06025)	1	
20	92995-06100-00	WASHER, SPRING	1	
21	92901-06600-00	WASHER	1	

# FUEL TANK

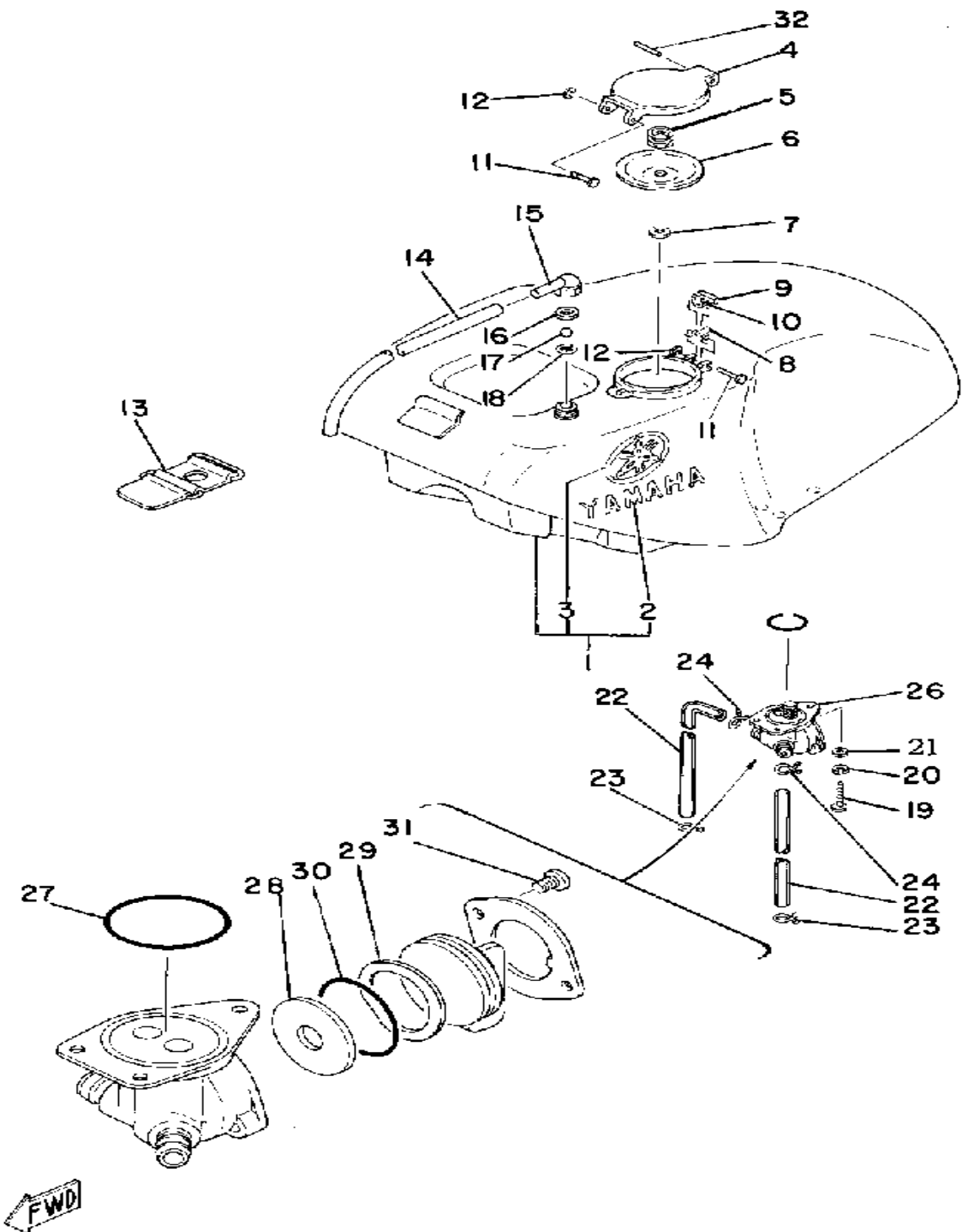

Ref. No.	Part Number	Description	Qty	Remarks
1	(3G2-24110-00-01)	FUEL TANK	1	
2	99225-00035-00	. EMBLEM 1	2	
3	1X2-24162-00-00	. EMBLEM 2	2	
4	294-24611-00-00	BODY, CAP	1	
5	90501-20130-00	SPRING, COMPRESSION	1	
6	294-24612-00-00	GASKET, CAP	1	
7	99009-06600-00	CIRCLIP	1	
8	90508-08223-00	SPRING, TORSION (256-24637-00)	1	
9	256-24628-00-00	HOOK	1	
10	93210-06632-00	O-RING	1	
11	90249-03016-00	PIN, SPEC'L SHAPE	2	
12	93430-02001-00	CIRCLIP	2	
13	240-24173-00-00	BAND, TNK FITTING 1	1	
14	90446-07094-00	HOSE (5-500) (308-15373-00)	1	
15	143-24681-00-00	NUT, CAP	1	
16	90430-10150-00	GASKET	1	
17	143-24684-00-00	BALL	1	
18	143-24685-00-00	CLIP, BALL HOLDER	1	
19	98580-05016-00	SCREW, PAN HEAD	4	
20	92990-05100-00	WASHER, SPRING	4	
21	92901-05600-00	WASHER, PLATE	4	
22	90445-11700-00	HOSE	1	
23	90467-10008-00	CLIP	2	
24	90467-11102-00	CLIP, SCISSOR	2	
25	90445-11374-00	HOSE (7-140)	1	
26	(3G2-24500-00-00)	FUEL COCK ASSEMBLY 1	1	
27	(3G2-24512-00-00)	GASKET	1	
28	16G-24523-00-00	. VALVE	1	

CONTINUED ON NEXT FRAME ►

# FUEL TANK

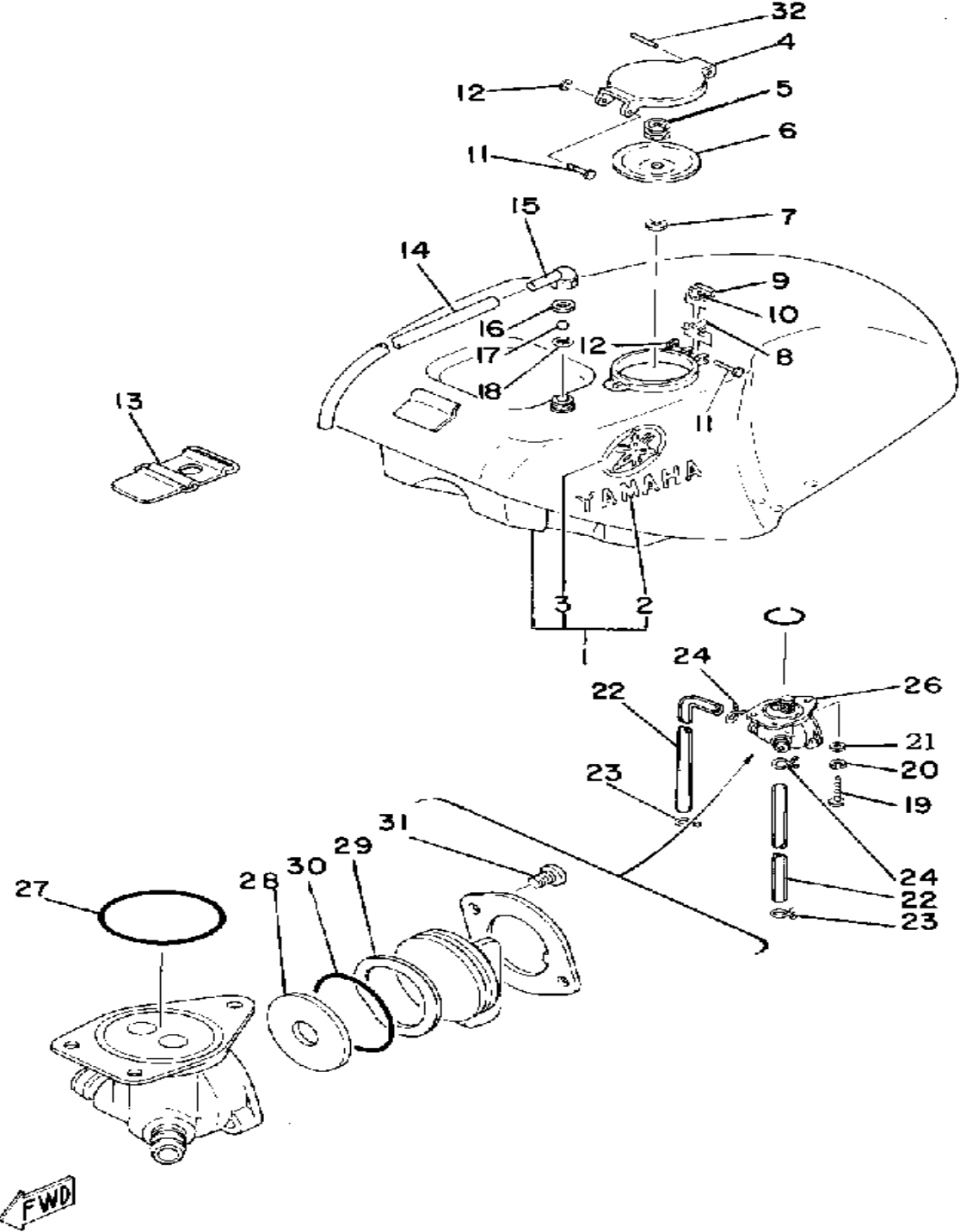

Ref. No.	Part Number	Description	Qty	Remarks
29	16G-24518-00-00	. WASHER, WAVE .....	1	
30	2G2-24534-00-00	. SEAL, COCK .....	1	
31	98580-03010-00	. SCREW, PAN HEAD (98502-03010) .....	2	
32	91609-25032-00	PIN, SPRING .....	1	



# SEAT

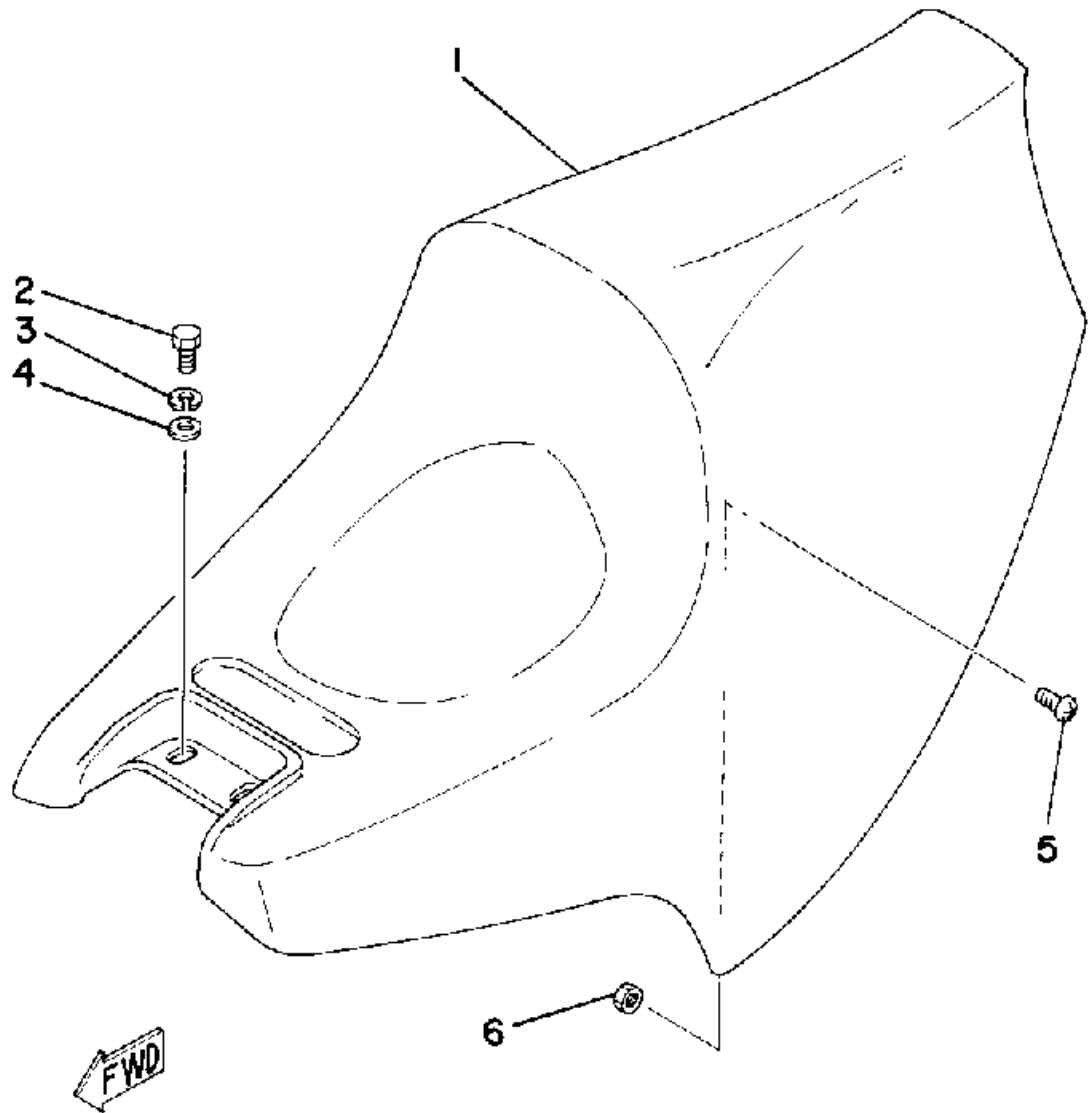

Ref. No.	Part Number	Description	Qty	Remarks
1	(3G2-24710-00-01)	SINGLE SEAT ASSEMBLY	1	
2	97011-06020-00	BOLT	2	
3	92995-06100-00	WASHER, SPRING	2	
4	90201-06057-00	WASHER, PLATE	2	
5	90140-06010-00	SCREW, ROUND HEAD (143-28353-00)	2	
6	90185-06040-00	NUT, SELF-LOCKING	2	

# FRONT WHEEL

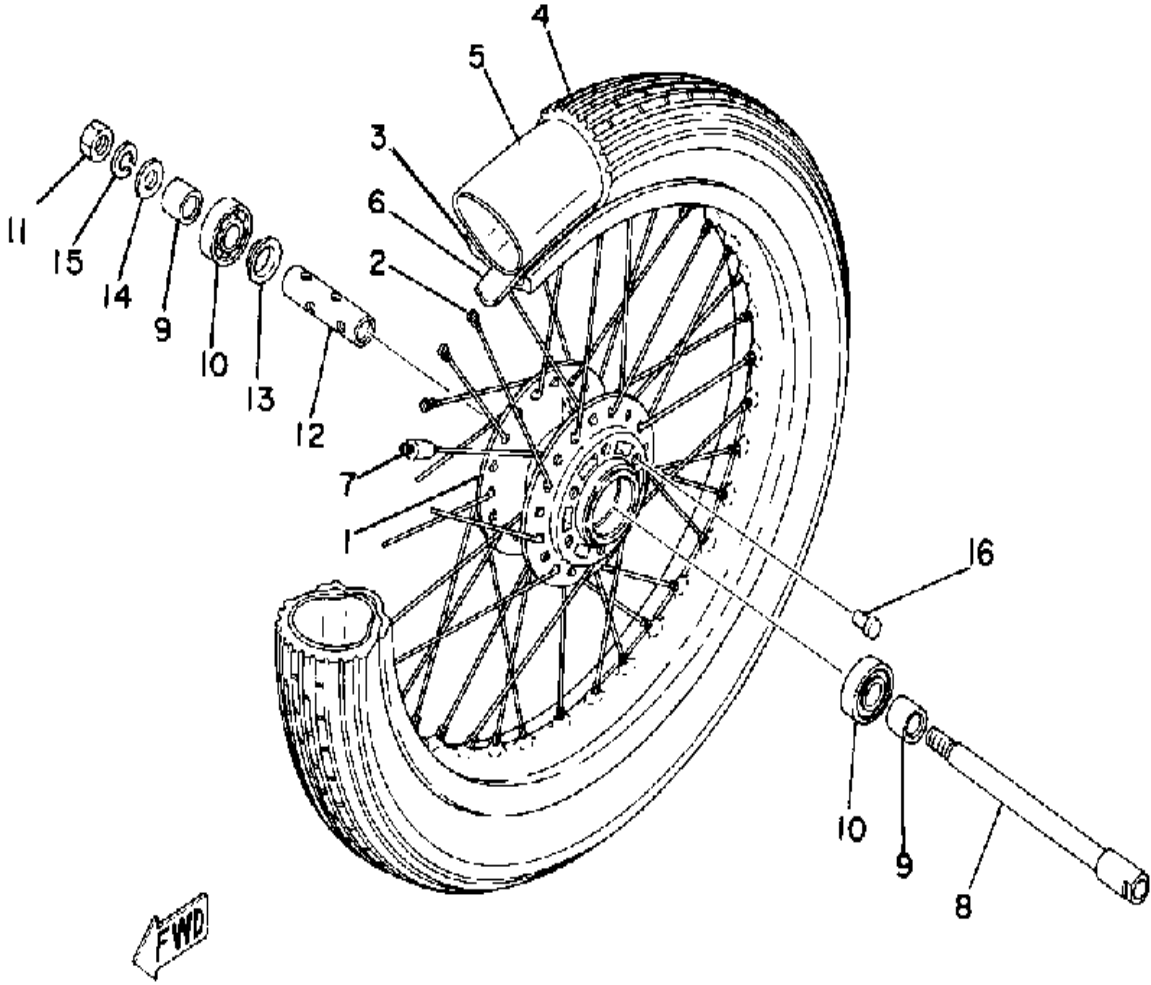

Ref. No.	Part Number	Description	Qty	Remarks
1	(1H3-25111-01-98)	HUB, FRONT	1	LOW GLOSS BLK
2	(409-25104-00-00)	SPOKE SET, FRONT	1	
3	(94418-18290-00)	RIM 1.85X 8	1	
5	(94230-18091-00)	TUBE	1	
6	(94325-18067-00)	BAND, RIM	1	
7	156-25398-00-00	BALANCER, WHEEL	1	
8	(409-25181-00-00)	AXLE, WHEEL	1	
9	(90387-17245-00)	COLLAR	2	
10	93306-30309-00	BEARING	2	
11	95312-14600-00	NUT	1	
12	(409-25117-00-00)	SPACER, BEARING	1	
13	146-25315-00-00	FLANGE, SPACER	1	
14	92990-14200-00	WASHER, PLAIN	1	
15	92901-14100-00	WASHER, SPRING	1	
16	90338-07011-00	PLUG, SPEC'L SHAPE	6	

# FRONT DISC BRAKE - CALIPER

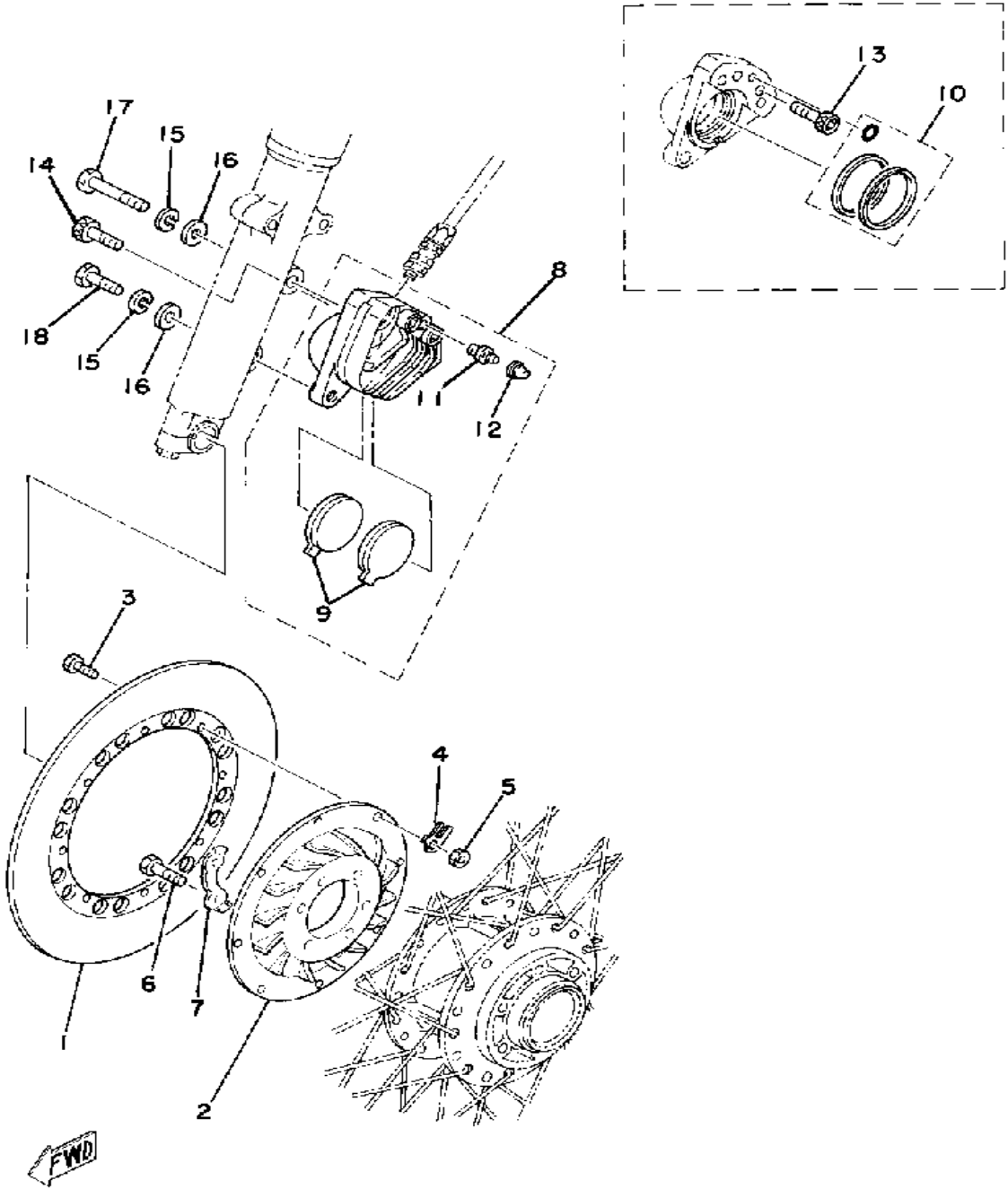

Ref. No.	Part Number	Description	Qty	Remarks
1	(409-25831-00-00)	DISC, BRAKE	1	
2	(409-25832-00-00)	BRACKET, DISC	1	
3	90109-06018-00	BOLT	8	
4	90215-06106-00	WASHER, LOCK (306-25834-00)	8	
5	95380-06600-00	NUT	8	
6	(90101-08272-00)	BOLT	6	
7	341-25412-00-00	WASHER	3	
8	1X2-25810-00-00	NO LONGER AVAILABLE	2	
9	(1X2-W0045-00-00)	BRAKE PAD KIT, FRNT	1	
10	1X2-W0047-00-00	. CALIPER SEAL KIT	1	
11	306-25824-00-00	. SCREW, BLEED	1	
12	306-25825-01-00	. CAP	1	
13	91316-10030-00	. BOLT, SOCKET HEAD	2	
14	91311-10040-00	BOLT	1	
15	92901-10100-00	WASHER, SPRING	2	
	92990-10100-00	WASHER, SPRING	2	
16	92990-10600-00	WASHER, PLATE	2	
17	(1X2-25818-50-00)	BOLT, CALIPER	1	
18	90109-10244-00	BOLT	1	

# REAR WHEEL

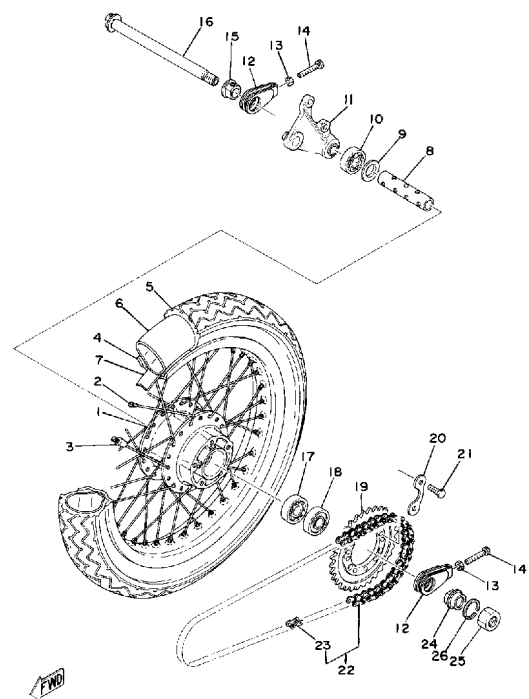

Ref. No.	Part Number	Description	Qty	Remarks
1	(1H3-25311-10-98)	HUB, REAR	1	LOW GLOSS BLK
2	(4A1-25304-00-00)	SPOKE SET, REAR	1	
3	156-25398-00-00	BALANCER, WHEEL	1	
4	(94421-18178-00)	RIM 2.15X 8	1	
6	(94230-18091-00)	TUBE	1	
7	(94325-18067-00)	BAND, RIM	1	
8	(1H3-25317-00-00)	SPACER, BEARING	1	
9	4V4-25315-00-00	FLANGE, SPACER	1	
10	93306-20404-00	BEARING	1	
11	(3G2-25819-00-00)	BRACKET, CALIPER	1	
12	3G2-25388-00-00	PULLER, CHAIN 1	2	
13	95303-08700-00	NUT	2	
14	90101-08699-00	BOLT	2	
15	(3G2-25384-00-00)	WASHER, WHEEL	1	
16	(3G2-25381-00-00)	AXLE, WHEEL	1	
17	93306-30421-00	BEARING (B6304C3)	1	
18	93306-30417-00	BEARING (B6304ZZ)	1	
19	(240-25442-00-00)	SPROCKET, DRIVN 42T	1	U.R.
	240-25432-00-00	SPROCKET, DRIVN 32T	1	U.R.
	240-25433-00-00	SPROCKET, DRIVN 33T	1	U.R.
	240-25434-00-00	SPROCKET, DRIVN 34T	1	U.R. STD
	240-25435-00-00	SPROCKET, DRIVN 35T	1	U.R.
	240-25438-00-00	SPROCKET, DRIVN 38T	1	U.R.
	3YL-25436-00-00	SPROCKET, DRIVEN 6	1	U.R.
	3YL-25437-00-00	SPROCKET, DRIVEN 7	1	U.R.
	3YL-25439-00-00	SPROCKET, DRIVEN 9	1	U.R.
	3YL-25440-00-00	SPROCKET, DRIVEN 0	1	U.R.
	3YL-25441-00-00	SPROCKET, DRIVEN 1	1	U.R.
20	143-25412-00-00	WASHER	3	

CONTINUED ON NEXT FRAME ►

# REAR WHEEL

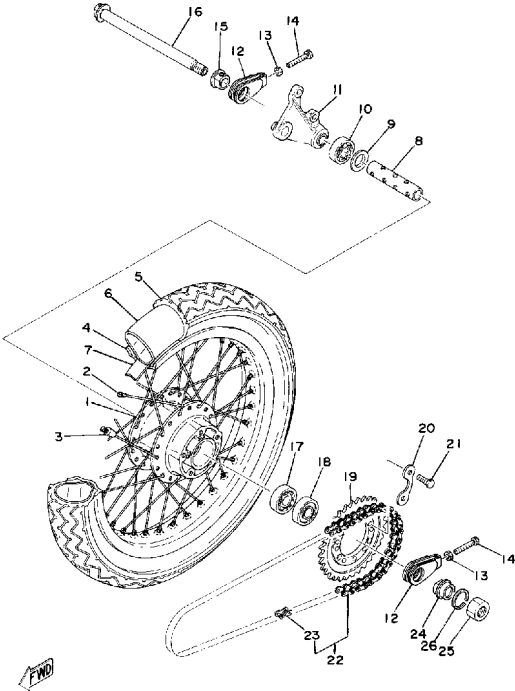

Ref. No.	Part Number	Description	Qty	Remarks
21	90109-08377-00	BOLT (214-25411-00)	5	
23	(94645-20031-00)	JOINT CHAIN	1	
24	(3G2-25377-00-00)	COLLAR, WHEEL	1	
25	90170-18091-00	NUT, HEXAGON	1	
26	92901-18100-00	WASHER, SPRING	1	



# FAIRING

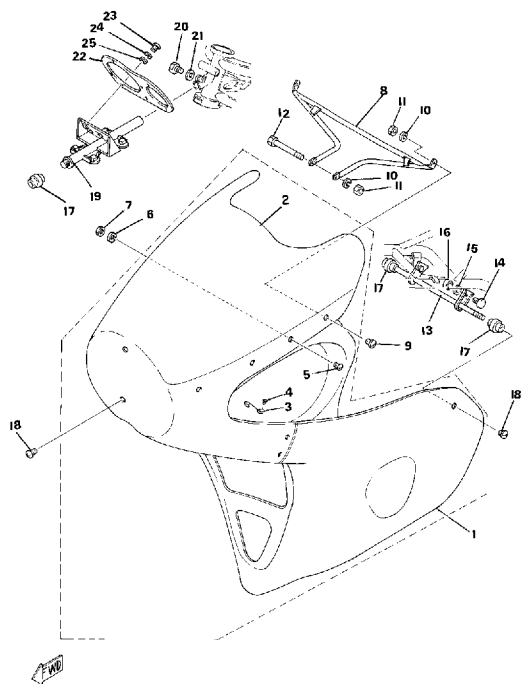

Ref. No.	Part Number	Description	Qty	Remarks
1	(ACC-11110-75-03)	TZ250F R.R.FAIRING	1	
2	(ACC-11110-77-04)	TZ750E WNDSHD ONLY	1	
3	(240-28388-00-00)	SPRING	7	
4	(90260-02002-00)	RIVET, ROUND HEAD	14	
5	90140-04012-00	SCREW, ROUND HEAD	7	
6	92901-04100-00	WASHER, SPRING	7	
7	95301-04700-00	NUT (95302-04700)	7	
8	(3G2-28357-00-00)	STAY 2	1	
9	90140-06010-00	SCREW, ROUND HEAD (143-28353-00)	2	
10	92995-06100-00	WASHER, SPRING	3	
11	95701-06300-00	NUT, NYLON	3	
12	97021-06080-00	BOLT (97001-06080-00)	1	
13	(240-28358-00-33)	STAY 3	1	YAMAHA BLACK
14	97313-08018-00	BOLT, HEXAGON (97301-08016)	2	
15	92990-08100-00	WASHER	2	
16	95333-08600-00	NUT	2	
17	240-28371-00-33	DAMPER	3	YAMAHA BLACK
18	90140-06010-00	SCREW, ROUND HEAD (143-28353-00)	3	
19	(3G2-28356-00-00)	STAY 1	1	
20	97313-08020-00	BOLT, HEXAGON	1	
21	92990-08100-00	WASHER	1	
22	(3V3-28358-00-00)	STAY 3	1	
23	98506-06016-00	SCREW, PANHEAD	2	
24	92995-06100-00	WASHER, SPRING	2	
25	90201-06057-00	WASHER, PLATE	2	

# METER

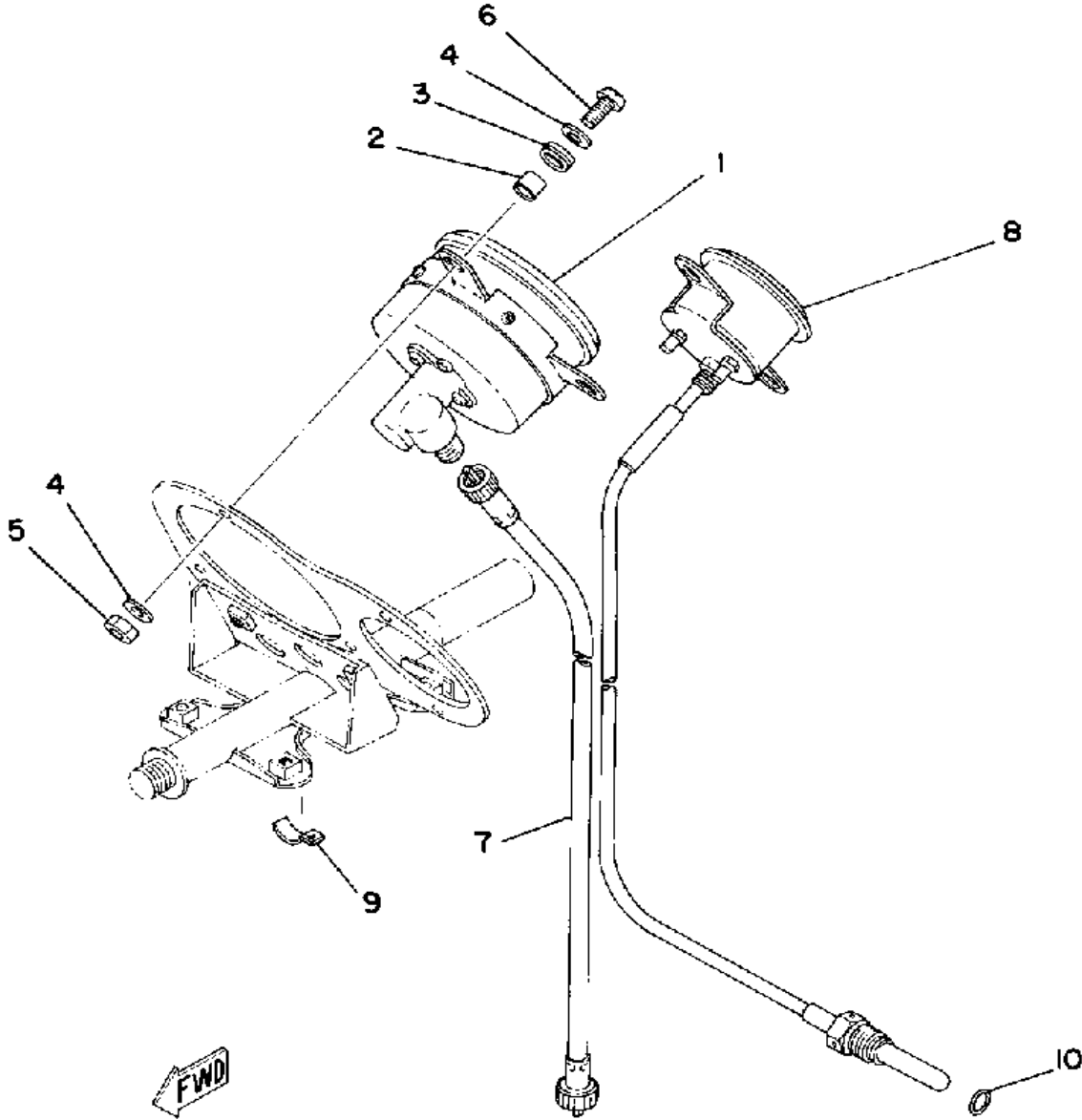

Ref. No.	Part Number	Description	Qty	Remarks
1	3G2-83540-00-00	TACHOMETER ASSEMBLY ...	1	
2	(90387-05715-00)	COLLAR .....	5	
3	90480-14103-00	GROMMET (214-21747-00) ....	5	
4	90201-05033-00	WASHER, PLATE .....	10	
5	95601-05100-00	NUT, U .....	5	
6	98506-05030-00	SCREW, PAN HEAD .....	5	
7	360-83560-01-00	TACHOMETER CABLE (360-83560-00) .....	1	
8	4A0-83590-01-00	WATER TEMP. ASSEMBLY ...	1	
9	90462-10007-00	CLAMP .....	2	
10	93210-10118-00	O-RING .....	1	



# ELECTRICAL

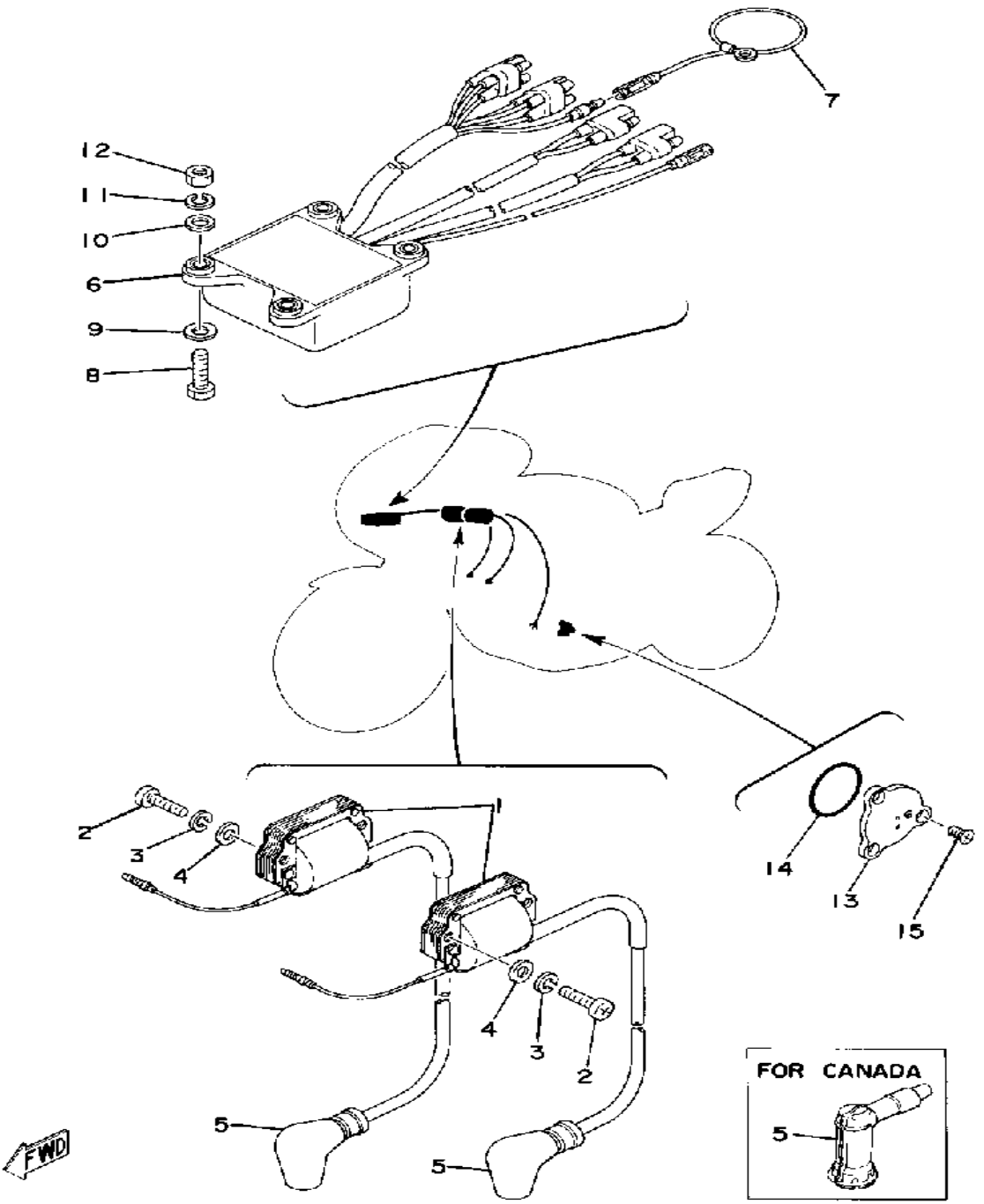

Ref. No.	Part Number	Description	Qty	Remarks
1	2X6-82310-10-00	IGNITION COIL ASSEMBLY ...	2	EXCEPT EUROPE*
2	98511-06025-00	SCREW PAN HEAD (92501-06025) .....	4	EXCEPT EUROPE
3	92995-06100-00	WASHER, SPRING .....	4	EXCEPT EUROPE
4	92990-06200-00	WASHER .....	4	EXCEPT EUROPE
5	294-82370-00-00	PLUG CAP ASSEMBLY .....	2	EXCEPT CANADA/EUROPE
	512-82370-10-00	PLUG CAP ASSEMBLY .....	2	FOR CANADA W/ NOISE SUPPRESS
6	328-85540-10-00	CDI UNIT ASSEMBLY .....	1	EXCEPT EUROPE
7	558-82116-00-00	WIRE, MINUS LEAD .....	1	EXCEPT EUROPE
8	97011-06025-00	BOLT (97001-06025) .....	4	EXCEPT EUROPE
9	90201-06M08-00	WASHER, PLATE .....	4	EXCEPT EUROPE
10	92990-06200-00	WASHER .....	4	EXCEPT EUROPE
11	92995-06100-00	WASHER, SPRING .....	4	EXCEPT EUROPE
12	95380-06600-00	NUT .....	4	EXCEPT EUROPE
13	1L9-82540-00-00	NEUTRAL SWITCH ASSEMBLY	1	
14	93210-29147-00	O-RING .....	1	
15	98701-05012-00	SCREW, FLAT HEAD .....	3	

FWD

